Nanoracks CubeSat Deployer (NRCSD) Interface Definition Document (IDD)

NRCSD



Doc No: NR-NRCSD-S0003

Revision: A



List of Revisions

Revision	Revision Date	Revised By	Revision Description
-	5/29/2018	Tristan Prejean	Initial Release
A	1/19/2024	Brenden Swanik	<ul style="list-style-type: none">- Updated Branding- Image updates- Updated examples inhibit schematic- Updated references- Added Unique Hazards Section<ul style="list-style-type: none">- Lasers- Permanent Magnets- 3d Printed Materials- High Voltage Section- Pressure System



Table of Contents

1	Introduction	6
1.1	Purpose	6
1.2	Scope	6
1.3	Usage	6
1.4	Exceptions	6
2	Acronyms, Definitions, and Applicable Documents	7
3	Nanoracks CubeSat Deployer System Overview	10
3.1	NRCSD Overview and Payload Capacity	10
3.2	NRCSD Coordinate System	10
3.3	NRCSD Design Features	11
3.4	NRCSD Operations Overview	12
3.4.1	Schedule	12
3.4.2	Ground Operations	13
3.4.3	On-Orbit Environments, Interfaces, and Operations	15
4	Payload Interface Requirements	22
4.1	Structural and Mechanical Systems Interface Requirements	22
4.1.1	CubeSat Mechanical Specification	22
4.1.2	CubeSat Mass Properties	25
4.1.3	RBF / ABF Access	25
4.1.4	Deployment Switches	26
4.1.5	Deployable Systems and Integration Constraints	26
4.1.6	Deployment Velocity and Tip-Off Rate Compatibility	26
4.2	Electrical System Interface Requirements	27
4.2.1	Electrical System Design and Inhibits	27
4.2.2	Electrical System Interfaces	28
4.3	Environmental Interface Requirements	29
4.3.1	Acceleration Loads	29
4.3.2	Random Vibration Environment	29
4.3.3	Launch Shock Environment	31
4.3.4	On-Orbit Acceleration	32
4.3.5	Integrated Loads Environment	32
4.3.6	Thermal Environment	33
4.3.7	Humidity	33
4.3.8	Airlock Depressurization	34
4.4	Safety Requirements	34
4.4.1	Containment of Frangible Materials	36
4.4.2	Venting	36
4.4.3	Secondary Locking Feature	37
4.4.4	Passivity	37
4.4.5	Pyrotechnics	37
4.4.6	Space Debris Compliance	37
4.4.7	Batteries	38
4.4.8	Pressure Vessels	42
4.4.9	Propulsion System	42

4.4.10	Materials	43
4.4.11	Electrical Bonding	44
4.5	Jettison Requirements	44
4.5.1	CubeSats with Propulsion	44
4.5.2	Re-entry Survivability	45
4.6	Documentation Requirements	45
4.6.1	Regulatory Compliance	45
4.6.2	Documentation	45
5	Requirements Matrix	46

List of Tables and Figures

Table 2-1: Acronyms.....	7
Table 2-2: Applicable Documents	9
Figure 3.1-1: Nanoracks CubeSat Deployer (NRCSD)	10
Figure 3.2-1: NRCSD Coordinate System.....	10
Figure 3.3-1: Nanoracks CubeSat Deployer Design Features.....	11
Table 3.4.1-1: Template Milestone Schedule.....	12
Figure 3.4.2.7-1: Sample NRCSD Stowage Configuration for Launch (NRCSD Quad-Pack in M2 CTB).....	15
Table 3.4.3.2-1: ISS Internal Environmental Conditions (Ref SSP 57121)	16
Figure 3.4.3.2-2: Operating Limits of the ISS Atmospheric Total Pressure, and Nitrogen and Oxygen Partial Pressures (Ref SSP 57121)	17
Figure 3.4.3.3-1: NRCSD Standard and DoubleWide on MPEP	18
Figure 3.4.3.4-1: JEM Airlock Slide Table	20
Figure 3.4.3.4-2: JEM Overview.....	20
Figure 3.4.3.4-3: NRCSD Deployment of Two (2) CubeSats from ISS (Photo Credit: NASA) ..	21
Figure 4.1.1-1: NRCSD Mechanical Interface (Dimensions in mm).....	23
Figure 4.1.1-2: NRCSD Payload Envelope Specification (Dimensions in mm).....	24
Table 4.1.2-1: CubeSat Mass Limits	25
Figure 4.2.1-1: CubeSat Electrical Subsystem Block Diagram (Note: RBF pins not shown) ...	28
Table 4.3.1-1: Launch Load Factors Envelope	29
Figure 4.3.2.1-1: Random Vibration Test Profiles	30
Table 4.3.2.1-1: Random Vibration Test Profiles	31
Table 4.3.4-1: On-Orbit Acceleration Environment	32
Table 4.3.6-1: Expected Thermal Environments	33
Table 4.6.2-1: Data Deliverables	46
Table 5-1: Nanoracks CubeSat Deployer Requirements Matrix.....	47



1 Introduction

1.1 Purpose

This Interface Definition Document (IDD) provides the minimum requirement set to verify compatibility of a small satellite with the Nanoracks CubeSat Deployer system (NRCSD). This IDD includes all applicable International Space Station (ISS) flight safety and interface requirements for payload use of the NRCSD. Nanoracks verifies compliance to all applicable requirements directly to the ISS Program on behalf of the Payload Developer (PD) based on incremental data requests.

1.2 Scope

This IDD is the sole requirements document for end users of the NRCSD (the PD or the Customer). The physical, functional, and environmental design requirements associated with payload safety and interface compatibility for flight with the NRCSD are included herein. The requirements defined in this document apply to all phases of the mission leading up to the deployment of the payload from the ISS, including both the pressurized and unpressurized operations on ISS. In some circumstances, the design requirements outlined in this document may also govern the operational, post-deployment mission phase of the payload. The interface requirements defined herein primarily address the Payload to NRCSD interface, but also include requirements derived from ISS Program safety documentation and interface control agreements with the Japan Aerospace Exploration Agency (JAXA).

1.3 Usage

This document levies design interface and verification requirements on payload developers (i.e. NRCSD satellite customers). These requirements are allocated to a payload through the unique payload Interface Control Agreement (ICA). The unique payload ICA documents the payload compliance with the requirements defined in this IDD. The ICA is utilized as the documentation tool to capture requirements verification approaches, data submittals, schedule updates, and any required exceptions.

1.4 Exceptions

Exception is the general term used to identify any payload developer-proposed departure from specified requirements or interfaces. Any exception to requirements, capabilities, or services defined in this IDD shall be documented in the ICA and evaluated to ensure that the stated condition is controlled and acceptable. The ICA will be revised throughout the payload design verification process and will document the specific requirement excepted, the exception number, the exception title, and the approval status.

2 Acronyms, Definitions, and Applicable Documents

Table 2-1: Acronyms

Acronym	Definition
ASD	Acceleration Spectral Density
BN	Ballistic Number
BoM	Bill of Materials
C&DH	Command & Data Handling
CMC	Cargo Mission Contract
CM	Center of Mass
CoC	Certificate of Compliance
COL	Columbus Module
COTS	Commercial Off-the-Shelf
CVCM	Collected Volatile Condensable Material
CTB	Cargo Transfer Bag
DFMR	Designed for Minimum Risk
DOT	Department of Transportation
EF	Exposed Facility
EPS	Electrical Power System
ESD	Electrostatic Discharge
ETFE	Ethylene tetrafluoroethylene
EVR	Extravehicular Robotics
FCC	Federal Communications Commission
FOD	Foreign Object Debris
GSE	Ground Support Equipment
HFIT	Human Factors Implementation Team
ICA	Interface Control Agreement
IDD	Interface Definition Document
I/F	Interface
ISS	International Space Station
ITU	International Telecommunication Union
JEM	Japanese Experiment Module
JEMRMS	Japanese Experiment Module Remote Manipulator System
JSC	Johnson Space Center
LCM	Launch Command Multiplexer

Acronym	Definition
MLI	Multi-Layer Insulation
MEFL	Maximum Expected Flight Level
MPEP	Multi-Purpose Experiment Platform
MSWG	Mechanical Systems Working Group
MWL	Minimum Workmanship Level
NASA	National Aeronautics and Space Administration
NLT	No Later Than
NOAA	National Oceanic and Atmospheric Administration
NRCSD	Nanoracks CubeSat Deployer
NRDD	Nanoracks DoubleWide Deployer
NTIA	National Telecommunications and Information Administration
ODAR	Orbital Debris Assessment Report
OLR	Outgoing Longwave Radiation
PCM	Pressurized Cargo Module
PD	Payload Developer
POIF	Payload Operations Integration Function
PTC	Positive Temperature Coefficient
PTFE	Polytetrafluoroethylene
ISRP	ISS Safety Review Panel
RBF	Remove Before Flight
RH	Relative Humidity
RSS	Root Sum Square
RTC	Real-Time Clock
SDP	Safety Data Package
SE&I	Systems Engineering & Integration
SMA	Shape Memory Alloy
TIM	Technical Interchange Meeting
TML	Total Mass Loss
US	United States
USL	U.S. Lab



Table 2-2: Applicable Documents

Doc No.	Rev	Title
JSC TA-92-038		Protection of Payload Electrical Power Circuits
JSC 20793	D	Crewed Space Vehicle Battery Safety Requirements
JX-ESPC-101193D	D	JEM System / Nanoracks CubeSat Deployer (NRCSD) Interface Control Document
MSFC-SPEC-522	B	DESIGN CRITERIA FOR CONTROLLING STRESS CORROSION CRACKING
NASA-STD-8719.14A	C	NASA Technical Standard Process for Limiting Orbital Debris
NASDA-ESPC-2903-B	B	JEM Payload Accommodation Handbook Vol. 6 Airlock/Payload Standard Interface Control Document
SSP 30233	H	Space Station Requirements for Materials and Processes
SSP 30245	P	Space Station Electrical Bonding Requirements
SSP 42004	K	Mobile Servicing System (MSS) to User (Generic) Interface Control Document Part 1
SSP 50835	D	ISS Pressurized Volume Hardware Common Interface Requirements Document
SSP 51721	-	ISS Safety Requirements Document
SSP 52005	F	Payload Flight Equipment Requirements and Guidelines for Safety-Critical Structures
SSP 57000	U	Pressurized Payloads Interface Requirements Document
SSP 57003	M	External Payload Interface Requirements Document

3 Nanoracks CubeSat Deployer System Overview

This section is an overview of the Nanoracks CubeSat Deployer (NRCSD) system and describes the various system interfaces and the operational elements of the payload lifecycle. The payload interface requirements are captured in Section 4.

3.1 NRCSD Overview and Payload Capacity

The NRCSD (see Figure 3.1-1) is a self-contained CubeSat deployer system for small satellites staged from the International Space Station (ISS). The NRCSD launches inside the Pressurized Cargo Module (PCM) of ISS cargo resupply vehicles and utilizes the ISS Japanese Experiment Module (JEM) as a staging facility for operation. The NRCSD is integrated with payloads on the ground at a Nanoracks facility prior to flight and mechanically and electrically isolates CubeSats from the cargo resupply vehicles, ISS, and ISS crew.



Figure 3.1-1: Nanoracks CubeSat Deployer (NRCSD)

The NRCSD is designed to accommodate any combination of 1U, 2U, 3U, 4U, or 5U CubeSats up to a maximum volume of 6U, or a single 6U CubeSat in the 1x6x1U configuration. The standard payload form factors and dimensional requirements are detailed in Section 4.

3.2 NRCSD Coordinate System

The NRCSD coordinate system is defined in Figure 3.2-1 (location of origin not considered).

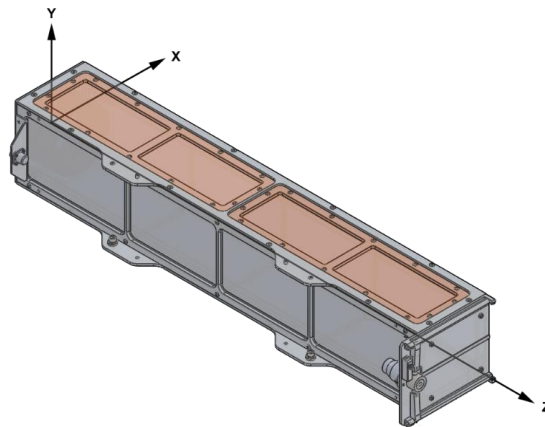

Figure 3.2-1: NRCSD Coordinate System

3.3 NRCSD Design Features

The NRCSD is a rectangular ‘silo’ that consists of four (4) sidewalls, a base plate, a pusher plate assembly with ejection spring, two (2) access panels, two (2) doors, and a primary release mechanism (see Figure 3.3-1). The deployer doors are located on the forward end (+Z face), the base plate assembly is located on the aft end (-Z face), and the access panels are on one side of the dispenser (+Y face). The inside walls of the NRCSD are smooth bore design to minimize and/or preclude hang-up or jamming of CubeSat appendages during deployment should these become released prematurely.

The release mechanism is a commercial off-the-shelf (COTS) mechanism with redundant channels; this component has an extensive space heritage. The integrated door design was completed by Nanoracks and has been designated ‘DFMR’, or Designed For Minimum Risk, by the Mechanical Systems Working Group (MSWG) at the Johnson Space Center (JSC).

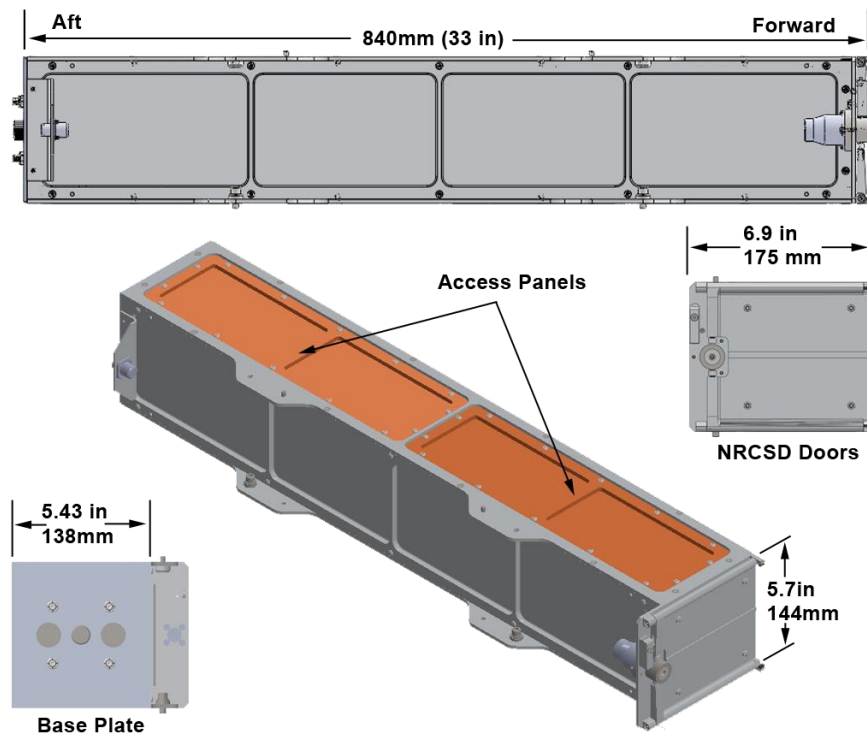

Figure 3.3-1: Nanoracks CubeSat Deployer Design Features



The NRCSD has a thumb screw that secures the NRCSD doors for flight. The thumb screw ensures that the primary release mechanism does not experience excess loading during the ground handling and ascent / launch portion of the mission. The NRCSD also has a jack screw and jam nut assembly that allows the integrated payload subsystem to be preloaded / secured in the Z axis for flight. The jack screw and jam nut assembly are installed on the deployer base plate. The thumb screw, jack screw, and jam nut are removed by the ISS crew prior to deployment operations. The NRCSD access panels are removed on the ground so that additional access is available during the payload fit-check and integration process. The access ports provide the only access for remove before flight (RBF) and / or apply before flight (ABF) features while the payloads are inside the NRCSD. The access panels are installed prior to handover for flight and are never opened on-orbit by the ISS crew.

3.4 NRCSD Operations Overview

3.4.1 Schedule

Table 3.4.1-1 is a template schedule outlining the major safety and hardware milestones for payload developers (PDs). The majority of the schedule milestones are related to the phased ISS safety review process with the ISS Safety Review Panel (ISRP) and the associated data milestones. The detailed payload schedule will be coordinated between Nanoracks and the payload developer and documented in the unique payload ICA.

Table 3.4.1-1: Template Milestone Schedule

Milestone/Activity	Launch-minus Dates (Months)
Feasibility Study / Contract Signing	L – 12
Regulatory Compliance Initiation by PD (Spectrum Coordination, Remote Sensing)	L – 12
Nanoracks / PD Kickoff Meeting	L-12
Interface Control Agreement (ICA) Initiation	L-12
Nanoracks / PD Safety Data Call Initiation	L-12
Baseline ICA	L-11
Phase 0/I Support Data from PD Complete	L-11
Phase 0/I Safety Data Package (SDP) Submittal to ISRP	L-10
Nanoracks / ISS Program Kickoff Meeting	L – 9.5
Phase 0/I Safety Review	L – 9
Phase 2 Support Data from PD Complete	L-8
Phase 2 SDP Submittal to ISRP	L-7
Phase 2 Safety Review	L-6



Milestone/Activity	Launch-minus Dates (Months)
ICA Signed by PD and Nanoracks	L-6
NRCSD and CubeSat Fit-Check	L-5
Payload Environmental Testing	L-5
ISS Program Required Flight Acceptance Testing	L-5
Phase 3 Support Data from PD Complete	L-4.5
Phase 3 SDP Submittal to ISRP	L-4
Phase 3 Safety Review	L-3.5
Regulatory Licensing in Place	L-3.5
Payload Delivery to Nanoracks	L-3.5
Nanoracks Cargo Handover to NASA	L-3

3.4.2 Ground Operations

3.4.2.1 Mechanical Fit-Check

Nanoracks will coordinate complete mechanical interface checks between the satellite and the NRCSD prior to final integration of the payload. Fit-checks are conducted with the hardware intended for flight. Use of flight-like engineering qualification hardware in lieu of flight models must be coordinated with Nanoracks and documented in the ICA.

3.4.2.2 Delivery to Nanoracks

The PD will deliver the complete payload to the Nanoracks Houston facility, or another facility as documented in the ICA, by the dates listed in the schedule for installation into the deployer. Any special requirements, such as ground support equipment (GSE), special handling instructions, cleanliness requirements, humidity requirements, ESD sensitivity, etc., shall be documented in the payload specific ICA.

3.4.2.3 Nanoracks Inspection

Nanoracks performs inspections of the payload to verify it meets the required safety and mechanical design requirements outlined in this IDD and the ICA. Typically, this includes, but is not limited to, mass properties and critical mechanical dimensions. This inspection takes place at the point of the fit-check and is repeated at the point that the payload is handed over to Nanoracks prior to final integration with the NRCSD. Note that any requirements that cannot be verified through inspection, measurements, and fit-check with the NRCSD must be verified via documentation and data submittals in advance of final payload delivery to Nanoracks.



3.4.2.4 Payload Developer Ground Servicing

The PD may perform payload activities at the Nanoracks facilities prior to final installation into the deployer, based on the agreements in the ICA, as long as these activities are within the scope of the documented and verified payload design. These payload activities may include post-shipment functional tests, battery charging, etc. Typically, these activities are completed prior to installation of the payload into the NRCSD. Note that the only access to the payload after the installation is complete is via the NRCSD access panels on the + Y face of the dispenser. No material or design changes shall be implemented at this phase of the processing. Once the payload has been delivered for flight to the ISS Cargo Mission Contract (CMC) team, no further payload servicing is permitted. The time between payload handover to Nanoracks and transfer to CMC is nominally about 1 week. Any post-delivery payload activities besides standard post-shipment receive and inspect procedures must be coordinated in advance and documented in the payload specific ICA.

3.4.2.5 Nanoracks Data Gathering for On-Orbit Operations

Nanoracks will assess the payload to develop products and procedures in support of on-orbit operations and crew interaction. Typically, no crew interaction with the CubeSats is permitted. Any request for crew interaction with the payload, including imagery requests during the deployment, must be coordinated with Nanoracks and documented via the unique payload ICA.

3.4.2.6 Nanoracks Testing

Although not normally required for CubeSats, Nanoracks may perform testing of the CubeSat based on the agreements made in the unique payload ICA. This may include, but is not limited to, support of vibration tests utilizing Nanoracks GSE, final charging of the payloads, visual and mechanical inspections, etc.

3.4.2.7 Nanoracks Packaging and Delivery

Nanoracks delivers the completed payload assembly to the ISS Cargo Mission Contract (CMC) team for incorporation into its final stowage configuration. This typically occurs approximately 1 week or less after Nanoracks receives the payload from the Customer. The payloads are delivered integrated with the NRCSD in flight configuration secured in ground packaging. The CMC team removes the integrated flight assembly from ground packaging and places into flight approved packing materials. The NRCSD is wrapped in bubble-wrap for flight and packed inside a foam-lined cargo transfer bag (CTB) prior to shipment of the hardware to the launch site and remains in this configuration for launch. Any specific packing requirements or orientation constraints of payloads shall be captured in the unique payload ICA.



Figure 3.4.2.7-1: Sample NRCSD Stowage Configuration for Launch (NRCSD Quad-Pack in M2 CTB)

3.4.2.8 Delivery to Launch Site

The CMC team is responsible for delivering the final stowed configuration to the appropriate launch site facility and for integration of the cargo into the ISS visiting vehicle.

3.4.3 On-Orbit Environments, Interfaces, and Operations

3.4.3.1 NRCSD Destow

Once the launch vehicle is on orbit and berthed, the ISS crew is responsible for transferring the integrated hardware assembly from the visiting vehicle to the on-orbit stowage location until it is time to deploy the CubeSats.



3.4.3.2 NRCSD On-Orbit Environments

The NRCSD is stowed inside the ISS prior to deployment operations. The on-orbit environmental information provided below is for design and analysis purposes.

Table 3.4.3.2-1: ISS Internal Environmental Conditions (Ref SSP 57121)

Environmental Condition	Value
Atmospheric Conditions on ISS	
Pressure Extremes	0 to 104.8 kPa (0 to 15.2 psia)
Normal operating pressure	See Figure 3.4.3.2-2
Oxygen partial pressure	See Figure 3.4.3.2-2
Nitrogen partial pressure	See Figure 3.4.3.2-2
Dew point	4.4 to 15.6 °C (40 to 60 °F)
Percent relative humidity	25 to 75%
Carbon dioxide partial pressure during normal operations with 6 crewmembers plus animals	24 hr. average exposure: 5.3 mm Hg Peak exposure: 7.6 mm Hg
Carbon dioxide partial pressure during crew change out with 11 crewmembers plus animals	24 hr. average exposure: 7.6 mm Hg Peak exposure: 10 mm Hg
Cabin air temperature in USL, JEM, and COL	18.3 to 26.7 °C (65 to 80 °F)
Cabin air temperature in Node 1	18.3 to 29.4 °C (65 to 85 °F)
Air velocity (Nominal)	0.051 to 0.203 m/s (10 to 40 ft/min)
Airborne microbes	Less than 1000 CFU/m ³
Atmosphere particulate level	Average less than 100,000 particles/ft ³ for particles less than 0.5 microns in size
General Illumination	108 Lux (10 fc) measured 30 inches from the floor in the center of the aisle
Ionizing Radiation Dose	Up to 30 Rads(Si) / year

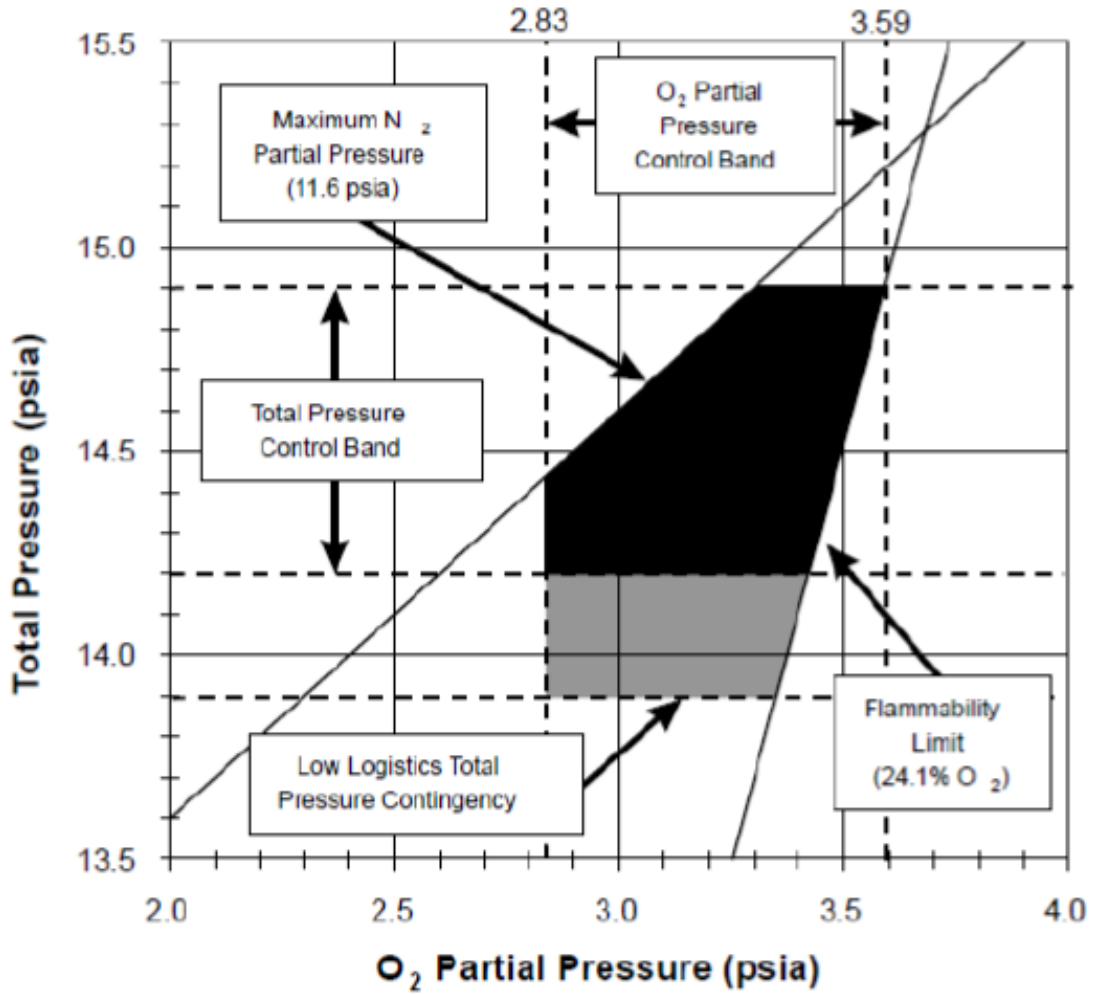

Figure 3.4.3.2-2: Operating Limits of the ISS Atmospheric Total Pressure, and Nitrogen and Oxygen Partial Pressures (Ref SSP 57121)

3.4.3.3 NRCSD On-Orbit Interfaces

The JEM Airlock is the facility on the ISS utilized to transport the NRCSD from the pressurized volume to the extra-vehicular environment of ISS. The NRCSD mounts to the Multi-Purpose Experiment Platform (MPEP), which in turn mounts to the JEM Airlock Slide Table. Depending on the mission complement, Nanoracks may deploy CubeSats using both the NRCSD and the Nanoracks DoubleWide Deployer (NRDD) on the same airlock cycle / mission. An example of an integrated NRCSD mission configuration on the MPEP is displayed in Figure 3.4.3.3-.

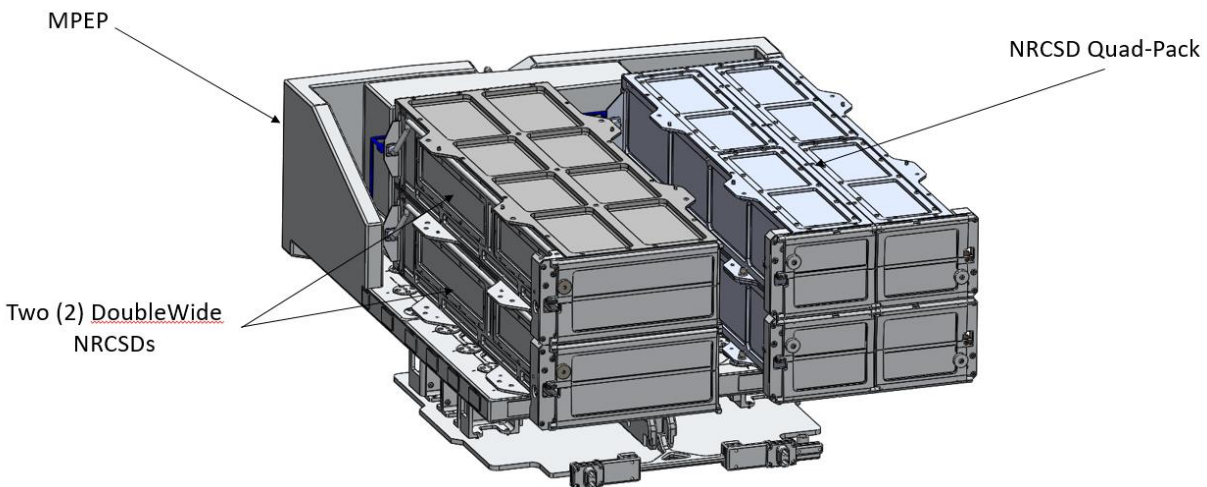

Figure 3.4.3.3-1: NRCSD Standard and DoubleWide on MPEP

A Multi-Layer Insulation (MLI) thermal blanket is secured around the NRCSD top-level mission assembly prior to JEM Airlock depress.

The JEM Remote Manipulator System (JEMRMS) is the Extravehicular Robotics (EVR) system that grapples the MPEP, removes the integrated assembly from the JEM airlock slide table, and positions the NRCSDs for deployment. The NRCSD release mechanism receives power from the Nanoracks Launch Command Multiplexer (LCM), which in turn receives power/data from the MPEP via the JEMRMS.

3.4.3.4 JEM Operation / Deployment from ISS

The JEM operations are managed by JAXA ground controllers. Once the ISS Program schedules the CubeSat deployment window (subject to various constraints such as visiting vehicle traffic, crew time, etc.) the on-orbit crew is responsible for unpacking the loaded NRCSDs and assembling the deployers onto the MPEP and JEM slide table (along with the LCM and associated cables). The Nanoracks operations team provides support to the crew in all aspects of the assembly in coordination with ISS Payload Operations Integration Function (POIF). The standard concept of operations for the NRCSD hardware is outlined below (see Figure 3.4.3.4-, Figure 3.4.3.4-, and Figure 3.4.3.4-):

- MPEP is installed onto the JEM Airlock Slide Table
- NRCSDs are mechanically installed on the MPEP along with the LCM
- NRCSD jack screws, jam nuts, and thumb screws are removed
- NRCSDs are electrically connected to the LCM, which in turn is connected to the MPEP using Nanoracks on-orbit cables
- The NRCSD/MPEP assembly is covered with an MLI thermal blanket
- The JEM Airlock Slide Table maneuvers the assembly into the airlock
- The JEM Airlock inner hatch is closed
- The JEM Airlock is depressurized
- The JEM Airlock outer hatch is opened
- The JEM Airlock Slide Table maneuvers outside the ISS
- The JEMRMS grapples the MPEP/NRCSD assembly by the grapple fixture located on the MPEP and translates it to the pre-approved deployment position (pointed retrograde to the ISS).
- JAXA ground controllers send the deployment command to the NRCSD via ISS CD&H backbone and then a single NRCSD deploys one silo of CubeSats. There may be more than one CubeSat in a single silo depending on the form factor. Deployment of the satellite(s) is captured by ISS external cameras to verify good deployment.
- The NRCSD/MPEP assembly is returned to the JEM Airlock and reverse steps taken to remove NRCSDs from JEM Airlock Slide Table
- NRCSDs are packed for return to Earth or on-orbit disposal on appropriate ISS cargo resupply vehicle

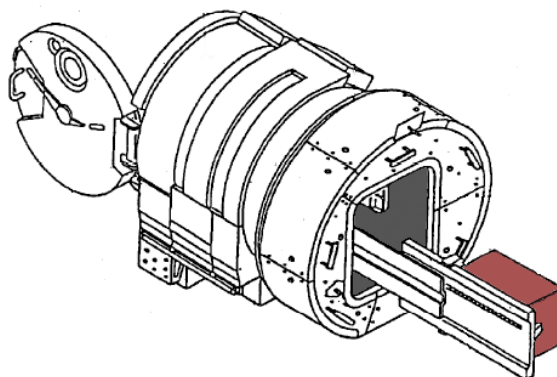

Figure 3.4.3.4-1: JEM Airlock Slide Table

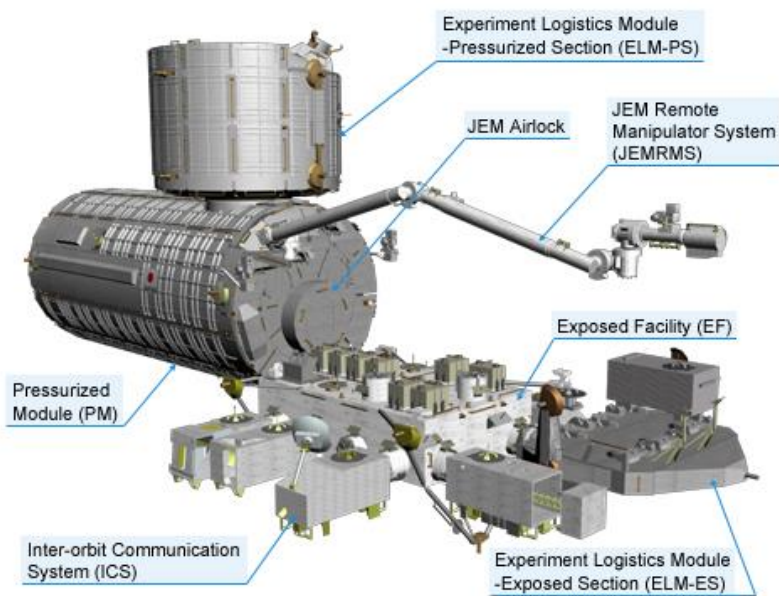

Figure 3.4.3.4-2: JEM Overview

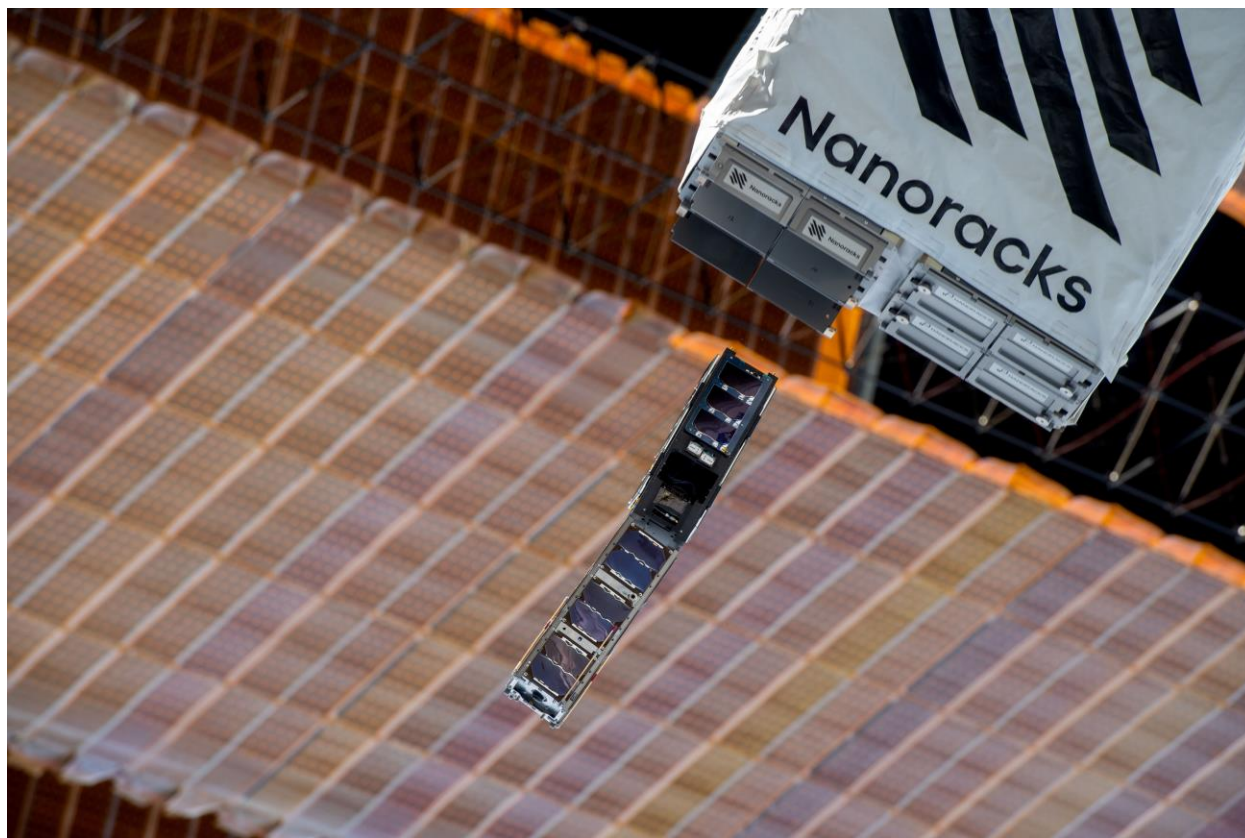

Figure 3.4.3.4-3: NRCSD Deployment of Two (2) CubeSats from ISS (Photo Credit: NASA)

4 Payload Interface Requirements

The requirements contained in this section shall be complied with in order to certify the payload for integration into the NRCSD, launch and stowage inside an ISS cargo resupply vehicle, and operation with the JEM module via the NRCSD and associated support hardware. The requirements are presented in the following categories: Structural and Mechanical Systems, Electrical, Environmental, Safety, Jettison, and Documentation. In the event a requirement cannot be adhered to, exceptions are often possible depending on the nature of the noncompliance. All required exceptions and associated acceptance rationale shall be captured in the unique payload ICA.

4.1 Structural and Mechanical Systems Interface Requirements

The NRCSD is designed to accommodate any combination of 1U, 2U, 3U, 4U, or 5U CubeSats up to a maximum volume of 6U, or a single 6U CubeSat in the 1x6x1U form factor. The only dimensional requirement that varies between the form factors is the total length (Z-axis dimension), which is specifically noted in the requirements herein. This section captures all mechanical and dimensional requirements to ensure the payloads interface correctly with the NRCSD and adjacent CubeSats.

4.1.1 CubeSat Mechanical Specification

- 1) The CubeSat shall have four (4) rails along the Z axis, one per corner of the payload envelope, which allow the payload to slide along the rail interface of the NRCSD as outlined in **Error! Reference source not found..**

- 2) The CubeSat rails and envelope shall adhere to the dimensional specification outlined in **Error! Reference source not found..**

Note: Any dimension followed by 'MIN' shall be considered a minimum dimensional requirement for that feature and any dimension followed by 'MAX' shall be considered a maximum dimensional requirement for that feature. Any dimension that has a required tolerance is specified in Figure 4.1.1-1. The optional cylindrical payload envelope (the 'tuna can') must be approved for use by Nanoracks and special accommodations may be required if utilizing this feature.

- 3) Each CubeSat rail shall have a minimum width (X and Y faces) of 6mm.
- 4) The edges of the CubeSat rails shall have a radius of 0.5mm +/- 0.1mm.
- 5) The CubeSat +Z rail ends shall be completely bare and have a minimum surface area of 6mm x 6mm.

Note: This is to ensure that CubeSat +Z rail ends can serve as the mechanical interface for adjacent CubeSat deployment switches / springs.

- 6) The CubeSat rail ends (+/-Z) shall be coplanar with the other rail ends within +/- 0.1mm.

- 7) The CubeSat rail length (Z axis) shall be the following (+/-0.1mm):

- a. 1U rail length: 113.50mm
- b. 2U rail length: 227.00mm

- c. 3U rail length: 340.50mm
- d. 4U rail length: 454.00mm
- e. 5U rail length: 567.5mm
- f. 6U rail length: 681 to 740.00mm

Note: Non-standard payload lengths may be considered. Any rail length differing from the above dimensions must be approved by Nanoracks and recorded in the unique payload ICA.

- 8) The CubeSat rails shall be continuous. No gaps, holes, fasteners, or any other features may be present along the length of the rails (Z-axis) in regions that contact the NRCSD rails.

Note: This does not apply to roller switches located within the rails. However, the roller switches must not impede the smooth motion of the rails across surfaces (NRCSD guide rails, fit gauge, etc.)

- 9) The *minimum* extension of the +/-Z CubeSat rails from the +/-Z CubeSat faces shall be 2mm.

Note: This means that the plane of the +/-Z rails shall have no less than 2mm clearance from any external feature on the +/-Z faces of the CubeSat (including solar panels, antennas, etc.)

- 10) The CubeSat rails shall be the only mechanical interface to the NRCSD in all axes (X, Y and Z axes).

Note: For clarification, this means that if the satellite is moved in any direction while inside the NRCSD, the only contact points of the payload shall be on the rails or rail ends. *No appendages or any part of the satellite shall contact the walls of the deployer.*

- 11) The CubeSat rail surfaces that contact the NRCSD guide rails shall have a hardness equal to or greater than hard-anodized aluminum (Rockwell C 65-70).

Note: Nanoracks recommends a hard-anodized aluminum surface.

- 12) The CubeSat rails and all load points shall have a surface roughness of less than or equal to 1.6 μm .

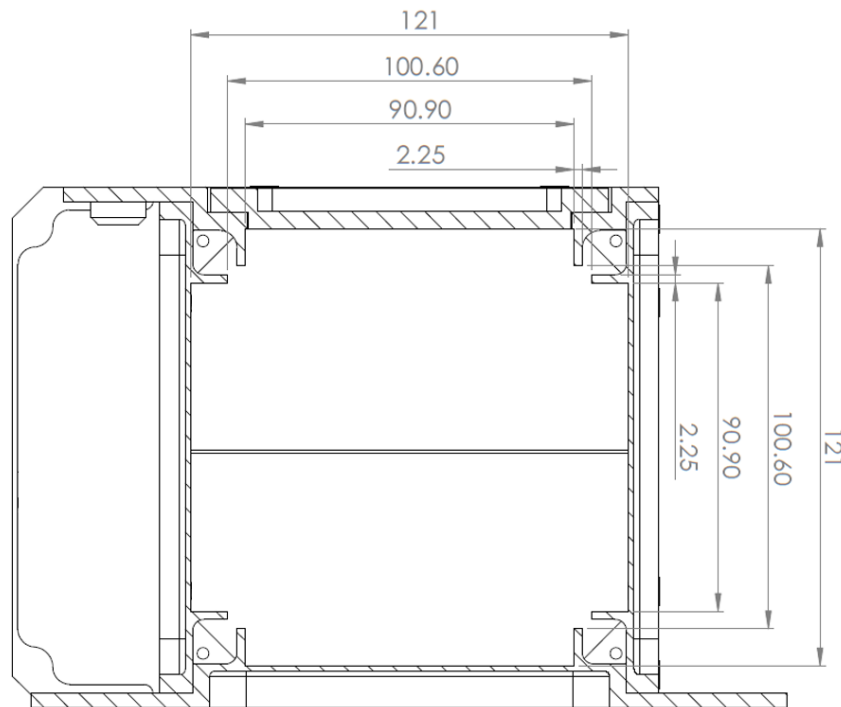

Figure 4.1.1-1: NRCSD Mechanical Interface (Dimensions in mm)

CubeSat Z-axis Rail-to-Rail Maximum Dimensions

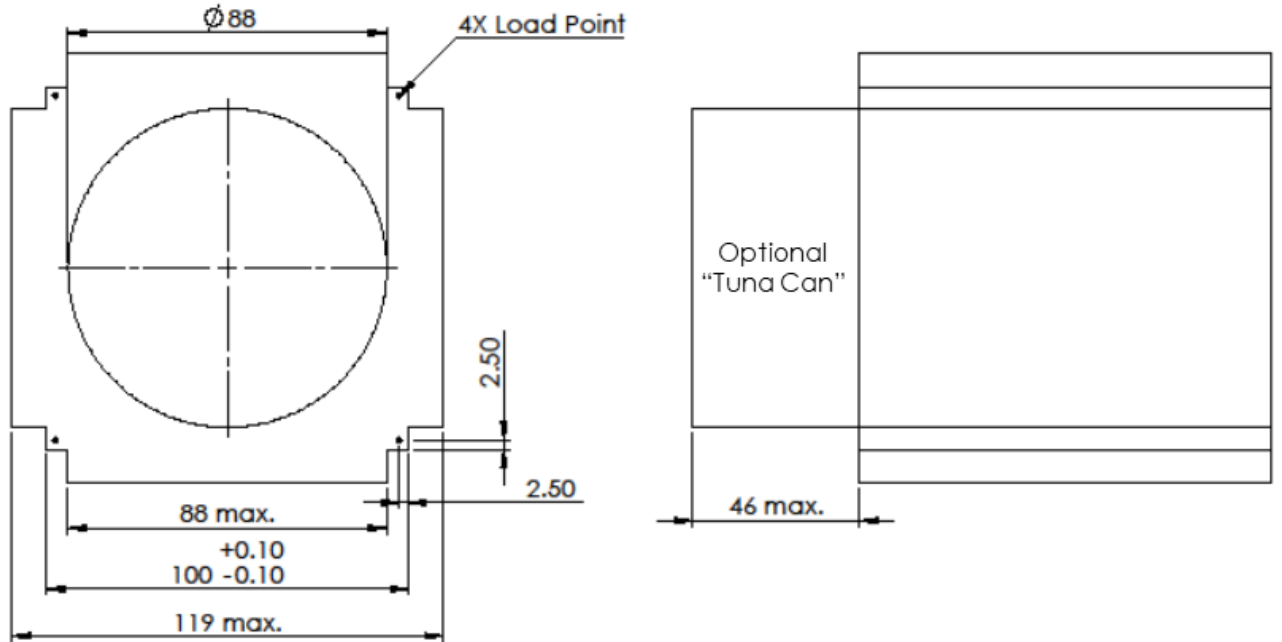
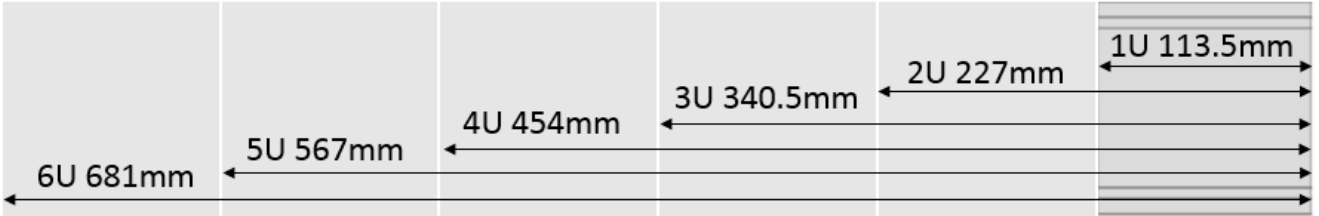

Figure 4.1.1-1: NRCSD Payload Envelope Specification (Dimensions in mm)

4.1.2 CubeSat Mass Properties

- 1) The CubeSat mass shall be less than the maximum allowable mass for each respective payload form factor per Table 4.1.2-1.

Note: The requirement driver for the CubeSat mass is the ballistic number (BN), which is dependent on the projected surface area of the payload on-orbit. The mass values in Table 4.1.2-1 assume no active or passive attitude control of the payload once deployed. If the CubeSat has attitude control capabilities or design features, then the operational ballistic number (BN) will drive the mass requirement. If applicable, this shall be captured in the unique payload ICA.

Table 4.1.2-1: CubeSat Mass Limits

Form Factor	Maximum Mass (kg)
1U	2.40
2U	3.60
3U	4.80
4U	6.00
5U	7.20
6U	8.40

- 2) The CubeSat center of mass (CM) shall be located within the following range relative to the geometric center of the payload.
 - a. X-axis: (+/- 2cm)
 - b. Y-axis: (+/- 2cm)
 - c. Z-axis:
 - i. 1U: (+/- 2cm)
 - ii. 2U (+/- 4cm)
 - iii. 3U (+/- 6cm)
 - iv. 4U (+/- 8cm)
 - v. 5U (+/- 10cm)
 - vi. 6U (+/- 12cm)

4.1.3 RBF / ABF Access

- 1) The CubeSat shall have a remove before flight (RBF) feature or an apply before flight (ABF) feature. The RBF / ABF shall be physically accessible via the NRCSD access panels on the +Y face of the dispenser.

Note: There is no physical access to the payload after integration into the NRCSD besides what can be accessed from the access panels.



4.1.4 Deployment Switches

- 1) The CubeSat shall have a minimum of two (2) deployment switches on the high side (cathode) of the main power system and a minimum of one (1) deployment switch on the low side (anode) of the main power system. These deployment switches (minimum of three (3) total) must correspond to independent electrical inhibits (see section on electrical interfaces).
- 2) Deployment switches of the pusher/plunger variety shall be located on the rail end faces of the CubeSat's -Z face.
- 3) Deployment switches of the roller/lever/slider variety shall be embedded in the CubeSat rails (+/- X or Y faces).
- 4) Roller/lever/slider switches shall maintain contact with 75% of the NRCSD rail width along the entire length of the rail.
- 5) The CubeSat deployment switches shall reset the payload to the pre-launch state if cycled at any time within the first 30 minutes after the switches close (including but not limited to radio frequency transmission and deployable system timers).
- 6) The CubeSat deployment switches shall be captive.
- 7) The force exerted by the deployment switches shall not exceed 3N.
- 8) The total force of all CubeSat deployment switches shall not exceed 9N.

4.1.5 Deployable Systems and Integration Constraints

- 1) CubeSat deployable systems (such as solar arrays, antennas, payload booms, etc.) shall have independent restraint mechanisms that do not rely on the NRCSD dispenser.
Note: Passive deployables that release upon ejection of the CubeSat from the NRCSD will be considered on a case-by-case basis with the concurrence of the ISRP.
- 2) The CubeSat shall be capable of being integrated forwards and backwards inside of the NRCSD (such that the +/-Z face could be deployed first without issue).
Note: In general, the deployables should be hinged towards the front of the deployer to mitigate risk of a hang-fire should the deployables be released prematurely while the CubeSat is still inside the NRCSD.

4.1.6 Deployment Velocity and Tip-Off Rate Compatibility

- 1) The CubeSat shall be capable of withstanding a deployment velocity of 0.5 to 2.0 m/s at ejection from the NRCSD.
- 2) The CubeSat shall be capable of withstanding up to five (5) deg/sec/axis tip-off rate.
Note: The target tip-off rate of the NRCSD is less than two (2) deg/sec/axis. If a payload has specific tip-off rate requirements, these should be captured in the unique payload ICA.

4.2 Electrical System Interface Requirements

CubeSat electronic system designs shall adhere to the following requirements.

4.2.1 Electrical System Design and Inhibits

- 1) All electrical power storage devices shall be internal to the CubeSat.
- 2) CubeSat shall not intentionally operate any mechanical, deployable, or communication systems (including RF transmitters, deployment mechanisms or other subsystems) for a minimum of 30 minutes post deployment where hazard potential exists. Satellites shall have a timer (set to a minimum of 30 minutes and require appropriate fault tolerance) before satellite operation or deployment of appendages where hazard potential exists. Please contact a Nanoracks Mission Manager for additional information.
- 3) The CubeSat electrical system design shall incorporate a minimum of three (3) independent inhibit switches actuated by physical deployment switches as shown in Figure 4.2.1-1. The satellite inhibit scheme shall include a ground leg inhibit (switch D3 on Figure 4.2.1-1) that disconnects the batteries along the power line from the negative terminal to ground.
Note: This requirement considers an inhibit as a power interrupt device. A control for an inhibit (electrical or software) cannot be counted as an inhibit or power interrupt device. The requirement for three (3) inhibits is based on the worst-case assumption that the CubeSat contains a potential catastrophic hazard that exists in the event of an inadvertent power-up while inside the NRCSD. However, the electrical system design shall incorporate an appropriate number of inhibits dictated by the hazard potential of the payload. If this requirement cannot be met, a hazard assessment can be conducted by Nanoracks to determine if an exception can be granted and documented in the unique payload ICA.
- 4) The CubeSat electrical system design shall not permit the ground charge circuit to energize the satellite systems (load), including flight computer (see Figure 4.2.1-1). This restriction applies to all charging methods.
- 5) The CubeSat shall have a remove before flight (RBF) feature or an apply before flight (ABF) feature that keeps the satellite in an unpowered state throughout the ground handling and integration process into the NRCSD.
Note: The RBF pin is required in addition to the three (3) inhibit switches. See Section 4.1.2 for details on mechanical access while the payload is inside the NRCSD.
- 6) The RBF /ABF feature shall preclude any power from any source operating any satellite functions with the exception of pre-integration battery charging.
- 7) The CubeSat Electrical Power System (EPS) shall have no more than six (6) inches of wire 26AWG or larger between the power source (i.e. battery pack) and the first electrical inhibit.
Note: If more than six (6) inches of wire is required between the batteries and the first electrical inhibit, additional testing and analysis may be required. Furthermore, SAE AS22759 or equivalent wiring shall be utilized, insulated with Polytetrafluoroethylene (PTFE) or Ethylene tetrafluoroethylene (ETFE), and adhere to the 200°C wire rating outlined on Page 2-8 of TA-92-038 (can be provided by Nanoracks).

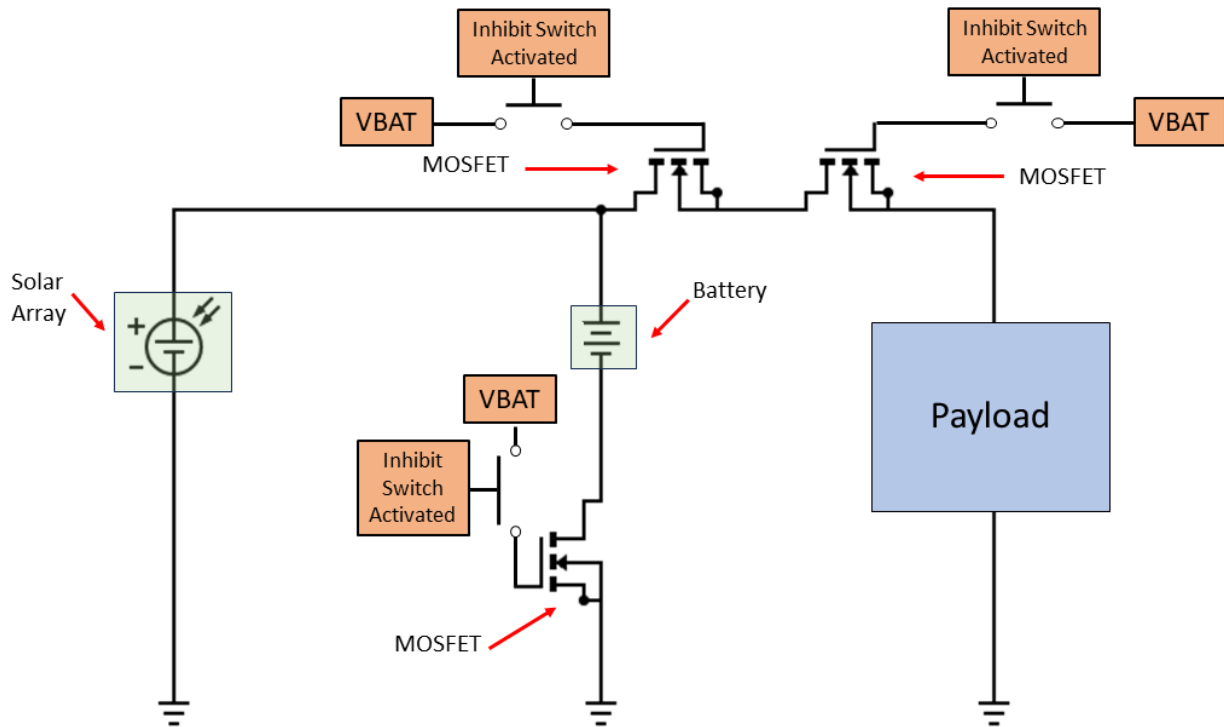

Figure 4.2.1-1: CubeSat Electrical Subsystem Block Diagram (Note: RBF pins not shown)

4.2.2 Electrical System Interfaces

- 1) There shall be no electrical or data interfaces between the CubeSat and the NRCSD. As outlined in Section 4.2, the CubeSat shall be completely inhibited while inside the NRCSD.

4.3 Environmental Interface Requirements

4.3.1 Acceleration Loads

- 1) Payload safety critical structures shall (and other payload structures *should*) provide positive margins of safety when exposed to the accelerations documented in Table 4.3.1-1 at the CG of the item, with all six degrees of freedom acting simultaneously.

Note: The acceleration values are applicable to both soft-stowed and hard-mounted hardware (Per SSP 57000, Section D.3.1.1). Nanoracks and the PD shall identify any safety critical structures in the unique payload ICA in order to determine what is required to verify this requirement. In general, all CubeSats structures are considered safety critical because failure of the CubeSat structure could produce untrackable space debris that could impact an ISS visiting vehicle (which is considered a catastrophic hazard by ISS Program).

Table 4.3.1-1: Launch Load Factors Envelope

	Nx (g)	Ny (g)	Nz (g)	Rx (rad/sec²)	Ry (rad/sec²)	Rz (rad/sec²)
Launch	+/- 7.0	+/- 4.0	+/- 4.0	+/- 13.5	+/- 13.5	+/- 13.5

Note: The RSS of Ny and Nz is +/-1.8 g, which can be applied one axis at a time in combination with the Nx load.

4.3.2 Random Vibration Environment

- 1) The CubeSat shall be capable of withstanding the random vibration environment for flight with appropriate safety margin as outlined in Section 4.3.2.1.

Note: The vibration test profiles vary depending on the configuration of the hardware during test (soft-stow or hard-mount). The different test options outlined below in Section 4.3.2.1 are based on guidance from the JSC Structural and Mechanical engineering branch (per JSC memo 'CubeSat Random Vibration (RV) Technical Requirements' dated October 24th, 2017). Specific post-vibration test inspection records are required to verify all external components are properly installed and do not pose a hazard of coming loose. Additional post-test inspection records may be required depending on the hazard classification of the CubeSat. The verification plan and all required inspection records are to be documented in the unique payload ICA.

4.3.2.1 Random Vibration Test Options

Since the NRCSD launches in the soft-stow configuration (wrapped in bubble wrap and secured in a foam-lined CTB, as outlined in Section 3.4.2.7), the satellites contained within the NRCSD are exposed to a soft-stow random vibration launch environment. This allows the payload developer to test in a flight equivalent configuration if desired. The acceptable random vibration test options for CubeSat payload developers are outlined below.

- 1) Random vibration test the flight article in the soft-stow flight configuration to the Maximum Expected Flight Level (MEFL) +3dB ('Soft-Stow Test Profile' in Figure 4.3.2.1-1 / Table 4.3.2.1-), for a duration of 60 seconds in each axis.

Note: Test configuration is the CubeSat integrated with the NRCSD or mechanically equivalent test fixture wrapped in flight approved bubble wrap and foam. Nanoracks must provide flight approved packing material for test.

- 2) Random vibration test the flight article in the hard-mount configuration to a combined test profile that envelopes the MEFL+3dB and a minimum workmanship level (MWL) vibrate ('Hard-Mount Test Profile' in Figure 4.3.2.1-1 / Table 4.3.2.1-), for a duration of 60 seconds in each axis.

Note: Test configuration is the CubeSat integrated with the NRCSD or mechanically equivalent test fixture bolted directly to a vibration table. This test profile also includes additional margin to the MEFL profile beyond that of the +3dB to account for potential amplification of the acceleration loads caused by the foam during flight.

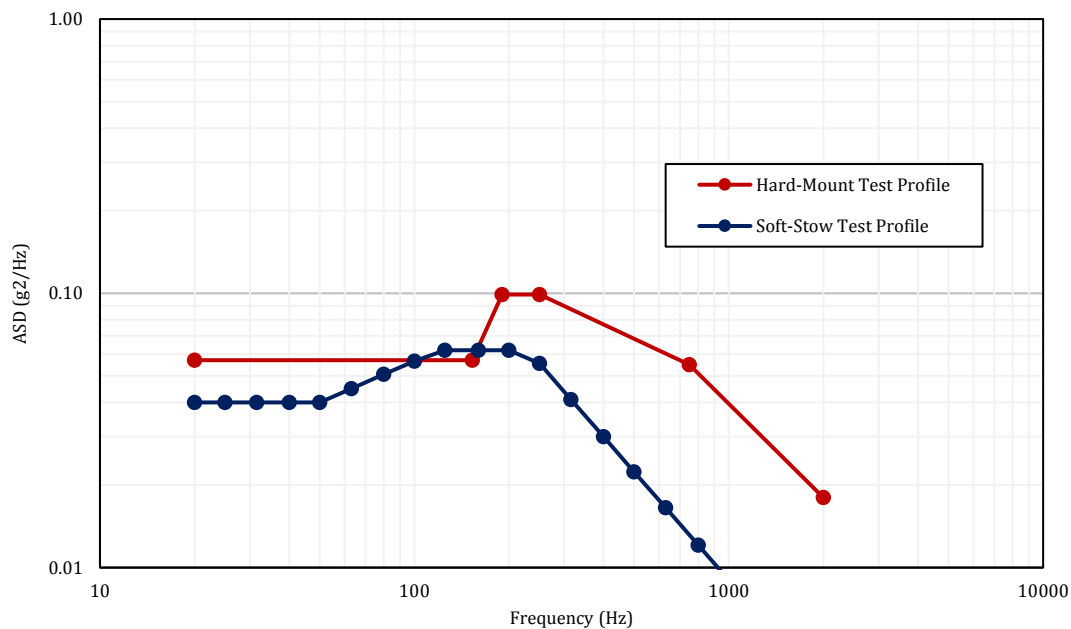

Figure 4.3.2.1-1: Random Vibration Test Profiles

Table 4.3.2.1-1: Random Vibration Test Profiles

Soft-Stow Test Profile	
Frequency (Hz)	ASD (g^2/Hz)
20	4.000E-02
25	4.000E-02
31.5	4.000E-02
40	4.000E-02
50	4.000E-02
63	4.490E-02
80	5.062E-02
100	5.660E-02
125	6.200E-02
160	6.200E-02
200	6.200E-02
250	5.558E-02
315	4.102E-02
400	2.998E-02
500	2.236E-02
630	1.651E-02
800	1.206E-02
1000	9.000E-03
1250	6.034E-03
1600	3.878E-03
2000	2.600E-03
grms	5.76
Duration (sec)	60

Hard-Mount Test Profile	
Frequency (Hz)	ASD (g^2/Hz)
20	5.700E-02
153	5.700E-02
190	9.900E-02
250	9.900E-02
750	5.500E-02
2000	1.800E-02
grms	9.47
Duration (sec)	60

4.3.3 Launch Shock Environment

Integrated end items packed in the soft-stow configuration do not experience significant mechanical shock. As a result, there is no shock test requirement for CubeSats launching inside the NRCSD. Any mechanical or electrical components on the spacecraft that are highly sensitive to shock should still be identified and assessed on a case-by-case basis as defined in the unique payload ICA.



4.3.4 On-Orbit Acceleration

The CubeSat shall be capable of withstanding the loads inside of the NRCSD when exposed to the acceleration environment defined in Table 4.3.4-1.

Table 4.3.4-1: On-Orbit Acceleration Environment

EVR Mission Phase	Acceleration	Reference Doc, Paragraph
On-Orbit Acceleration	2.0 m/sec ²	JX-ESPC-101133-B, 2.4.2(a)
Acceleration During Airlock Carry Out	1.5 m/sec ²	NASDA-ESPC-2903, 4.1.3.3
Acceleration induced by JEMRMS Emergency-Stop	0.69 m/sec ²	JX-ESPC-101133-B, 2.4.2(b)

Note: These loads are enveloped by the launch, ground handling, and quasi-static analysis loads. No verification data shall be required.

4.3.5 Integrated Loads Environment

The CubeSat shall be capable of withstanding a force of 1200N across all rail ends in the Z axis.

Note: This number is conservative and will be refined based on qualification testing and further analyses by Nanoracks.

4.3.6 Thermal Environment

The CubeSat shall be capable of withstanding the expected thermal environments for all mission phases, which are enveloped by the on-orbit, EVR phase prior to deployment. The expected thermal environments for all phases of the mission leading up to deployment are below in Table 4.3.6-.

Note: The on-orbit temperature extremes for the EVR phase prior to deployment are to be considered worst-case extremes based on the results of the thermal analysis conducted for the NRCSD. The thermal analysis was conducted based on worst-case atmospheric conditions that are expected to be exceeded no more than 0.5% of the time, with albedo and outgoing longwave radiation (OLR) adjusted to the top of the atmosphere (30-kilometer altitude) per SSP 41000 Table XXV. The solar loading conditions for these also took into account extreme beta angle conditions of 73 degrees and -60 degrees as dictated by JAXA.

Table 4.3.6-1: Expected Thermal Environments

Mission Phase	Temperature Extremes
Ground Transport (Customer facility to Nanoracks)	Determined for each payload
Ground Processing Nanoracks	Determined for each payload
Ground Processing NASA / JAXA Envelope	10°C to 35°C
Dragon Pressurized Cargo	18.3°C to 29.4°C
Cygnus Pressurized Cargo	10°C to 46°C
HTV Pressurized Cargo	0°C to 50°C
On-orbit, Pre-deployment, U.S. and JEM Modules	16.7°C to 28.3°C
On-orbit, EVR Prior to Deployment	-10°C to 45°C

Ref SSP 50835, Table E.2.10-1

4.3.7 Humidity

The CubeSat shall be capable of withstanding the relative humidity environment for all mission phases leading up to deployment, which is between 25% to 75% relative humidity (RH) for ascent and on-orbit phases of flight.

Note: Special consideration may be possible for payload with more stringent RH requirements. These requirements shall be captured in the unique payload ICA and special handling requirements negotiated directly with Nanoracks.



4.3.8 Airlock Depressurization

The CubeSat shall be capable of withstanding the pressure extremes and depressurization / pressurization rate of the airlock as defined below.

Airlock Pressure: 0 to 104.8 kPa

Airlock pressure depressurization/re-pressurization rate: 1.0 kPa/sec

Note: Verification of this requirement completed by ensuring the payload adheres to the venting requirements outlined in Section 4.4.2.

4.4 Safety Requirements

CubeSats shall be designed to preclude or control all hazards present according to the requirements and guidelines outlined in this section. The following sections contain the specific safety requirements common to standard CubeSat designs. In many cases though, the specific design requirements are dependent on the hazard classification of the CubeSat (particularly for CubeSats with non-standard design features). While Nanoracks is responsible for performing the hazard classification for all payloads (with ultimate concurrence from the ISRP), the general guidelines of the process have been outlined below and should be considered background info for the PD.

In general, hazards are classified according to the following definitions:

- 1) **Catastrophic** Hazard Definition – Any condition that may result in the potential for:
 - A disabling or fatal personnel injury,
 - Loss of the ISS,
 - Loss of a crew-carrying vehicle
 - Loss of a major ground facility

SSP 57121 paragraph 4.1.1.3 Catastrophic HAZARDS - The payload shall be designed such that no combination of two failures, two operator errors (or one of each), can cause a disabling or fatal personnel injury or loss of one of the following: loss of ISS, loss of a crew-carrying vehicle, or loss of major ground facility.

- 2) **Critical** Hazard Definition - Any condition that may result in either:
 - A non-disabling personnel injury or illness
 - Loss of a major ISS element
 - Loss of redundancy (i.e. with only a single hazard control remaining) for on-orbit life sustaining function

SSP 51721 paragraph 4.1.1.2 CRITICAL HAZARDS - The payload shall be designed such that no single failure or single operator error can cause a non-disabling personnel injury or illness, loss of a major ISS element, loss of redundancy (i.e. with only a single hazard control remaining) for on-orbit life sustaining function, or loss of use of the Space Station Remote Manipulator System (SSRMS).

3) Marginal Hazard Definition - Any condition which may cause damage to:

- An ISS element in a non-critical path
- A personnel injury causing minor crew discomfort that does not require medical intervention from a second crewmember and/or consultation with a Flight Surgeon

Some examples of CubeSat features/failures that are assessed for hazard potential are:

- Structure Failure
 - Inability to sustain applied loads
 - Fracture
 - Stress corrosion
 - Mechanisms
 - Fastener integrity and secondary locking features
- Pressure System Failure
 - Explosion
 - Rupture
- Leakage of, or exposure to, hazardous or toxic substances
- Propulsion System Hazards
 - Including inadvertent operation
- Deployment of appendages
- RF system operation hazard to ISS hardware and Crew
- Battery Failure
- Flammable or toxic material usage
- Frangible material usage
- Electrical system failures causing shock or burn
 - Includes wiring, fusing, grounding
- Electromagnetic Interference (EMI)
- Magnetic field
- Collision with ISS or Visiting Vehicles post deploy on subsequent orbits
- Operational procedures

Control of hazards shall be appropriate for the hazard type and occurrence. Many CubeSat Hazards are controlled by the deployer itself since the CubeSat is contained in the deployer while at ISS until deployment. Some examples of other controls are:

- Structural hazards
 - Application of factor of safety with positive margin
 - Supports design for minimum risk
 - Fault tolerance where applicable
 - Controlled by remaining elements not failing under resulting load
 - Redundant mechanisms
- Electrically operated systems
 - Inhibits to control inadvertent operations appropriate to the hazard level
 - Redundancy as necessary to perform required functions
 - Design controls

- Leakage of toxic substances
 - Fault tolerance in seals
 - Structural strength of containers
 - Multiple levels of containment
- Flammable materials
 - Elimination of flammable materials
 - Containment
 - Wire sizing and fusing
- Pressure systems
 - Factor of safety
 - Venting
- RF systems
 - Design to have power below hazard level and frequency in approved range
 - Inhibits to control inadvertent operations appropriate to the hazard level
- Battery hazards
 - Containment
 - Protection circuits
 - Separation to prevent thermal runaway propagation
 - Screening and testing

4.4.1 Containment of Frangible Materials

The CubeSat design shall preclude the release or generation of any foreign object debris (FOD) for all mission phases.

Note: The primary concern is exposed frangible materials on the satellite exterior (solar cell cover glass, optical lenses, etc). For most frangible materials on CubeSats, a containment or protection method is not required (however all frangible materials shall be identified in the payload unique ICA for Nanoracks review).

4.4.2 Venting

The Maximum Effective Vent Ratio (MEVR) of the CubeSat structure and any enclosed containers internal to the CubeSat shall not exceed 5080cm.

The MEVR is calculated as follows:

$$MEVR = \left(\frac{\text{Internal Volume (cm)}^3}{\text{Effective Vent Area (cm)}^2} \right) \leq 5080 \text{ cm}$$

Effective vent area shall be considered as the summation of the unobstructed surface area of any vent hole locations or cross-sectional regions that air could escape the CubeSat or subsystems.



4.4.3 Secondary Locking Feature

The CubeSat shall have an approved secondary locking feature for any and all fasteners or subcomponents external to the CubeSat chassis that would not be held captive by the spacecraft structure should it come loose.

Note: The measured and recorded fastener torque is considered the primary locking feature for fasteners. Mechanical or liquid locking compounds are approved. Mechanical secondary locking features are preferred and may be either a locking receptacle such as a locking helical insert or locknut. Approved thread locking compounds include Loctite® Threadlocker Red 271™ and Blue 242™. Contact Nanoracks to determine what other commonly used locking compounds have been approved for use and for appropriate application instructions. The secondary locking feature for all external fasteners and the application procedure of all liquid locking compounds shall be approved by Nanoracks and documented in the unique payload ICA.

4.4.4 Passivity

The CubeSat shall be passive and self-contained from the time of integration up to the time of deployment.

Note: No charging of batteries, support services, and or support from ISS crew is provided after final integration.

4.4.5 Pyrotechnics

The CubeSat shall not contain any pyrotechnics unless the design approach is approved by Nanoracks.

Note: Electrically operated melt-wire systems for deployables that are necessary controls for hazard potentials are permitted.

4.4.6 Space Debris Compliance

- 1) CubeSats shall not have detachable parts during launch or normal mission operations. Any exceptions will be coordinated with Nanoracks and documented in the unique payload ICA.
- 2) CubeSats shall comply with NASA space debris mitigation guidelines as documented in NASA Technical Standard NASA-STD-8719.14A.

4.4.7 Batteries

All cells / batteries on the CubeSat shall adhere to the design and testing requirements for spacecraft flight onboard or near the ISS as derived from the NASA requirement document JSC 20793 Crewed Space Vehicle Battery Safety Requirements. Specific provisions for battery use are designed to assure that a battery is safe for ground personnel and ISS crew members to handle and/or operate during all applicable mission phases and particularly in an enclosed environment of a crewed space vehicle. These NASA provisions also assure that the battery is safe for use in launch vehicles, as well as in unpressurized spaces adjacent to the habitable portion of a space vehicle. The required provisions encompass hazard controls, design evaluation, and verification. Evaluation of the battery system must be complete prior to certification for flight and ground operations. Certain battery cell chemistries and battery configurations may trigger higher scrutiny to protect against thermal runaway propagation.

It is imperative that Nanoracks receive all requested technical data as early as possible to assure the necessary safety features are present to control the hazards associated with a particular battery design and to identify all necessary verifications and testing required (as documented in the unique payload ICA). Redesign efforts greatly impact the payload developer both in cost and schedule. Consult with Nanoracks before hardware is manufactured. Cell/Battery testing associated with the verification of the safety compliance shall be completed as part of the safety certification of the spacecraft. To comply with the requirements herein, every battery design, along with its safety verification program, its ground and/or on-orbit usage plans, and its post-flight processing shall be evaluated and approved by the appropriate technical review panel in the given program or project and captured in the unique payload ICA.

4.4.7.1 Battery Hazards

The possible sources of battery hazards are listed below and shall be identified for each battery system. Applicable hazards will be evaluated to determine and to identify design, workmanship, and other features to be used for hazard control (electrical, mechanical, and/or thermal).

Potential Battery Hazards:

- Fire/Explosion/Flammability
- Venting/Burst of Battery Enclosure
- Overcharge Failure/Over-discharge Failure
- External Short Circuit
- Internal Short Circuit Failure
- Thermal Runaway Propagation/Extreme Temperature Hazards
- Chemical Exposure Hazards

4.4.7.2 Battery Types

Although any battery may be made safe to fly in the crewed space vehicle environment there are some batteries that are not practical to make safe. For example, lithium-sulfur dioxide cells have built-in overpressure vents that will release SO₂ (sulfur dioxide) gas and other electrolyte components that are highly toxic; thus, these are unacceptable in the habitable area of a space vehicle. However, these chemistries have been used safely in the non-pressurized areas of crewed spacecraft. Often the cells used in batteries for crewed space vehicle are commercially available.

Battery types typically used in spacecraft include (Per JSC 20793 REV. D):

- Alkaline-manganese primary
- LeClanche (carbon-zinc) primary
- Lead-acid secondary cells having immobilized electrolyte
- Lithium/lithium-ion polymer secondary (including lithium-polymer variation)
- Lithium metal anode primary cells having the following cathodic (positive) active materials
 - Poly-carbon monofluoride
 - Iodine
 - Manganese dioxide
 - Silver chromate
 - Sulfur dioxide (external to habitable spaces only)
 - Thionyl chloride
 - Thionyl chloride with bromine chloride complex additive (Li-BCX)
 - Iron disulfide
- Lithium sulfur
- Mercuric oxide-zinc primary
- Nickel-cadmium secondary
- Nickel-hydrogen secondary
- Nickel-metal hydride secondary
- Silver-zinc primary and secondary

Note: Pressurized battery chemistries require coordination with Nanoracks.

4.4.7.3 Required Battery Flight Acceptance Testing

All flight cells and battery packs shall be subjected to an approved set of acceptance screening tests to ensure the cells will perform in the required load and environment without leakage or failure. While the specific test procedures vary depending on the type of battery, the majority of Lithium ion or Lithium polymer cells / batteries used in CubeSats can be tested to a standard statement of work issued by Nanoracks (NR-SRD-139). Some generic battery design requirements are outlined below.

Note: The battery test plan and verification approach shall be captured in the payload unique ICA. No testing shall be performed without the approval of Nanoracks.

4.4.7.4 Internal Short

Protection circuitry and safety features shall be implemented at the cell level to prevent an internal short circuit.

- Application of all cells shall be reviewed by Nanoracks.
- Charger circuit and protection circuit schematics shall be reviewed and evaluated for required fault tolerance.

4.4.7.5 External Short

Protection circuitry and safety features shall be implemented at the cell level to prevent an external short circuit.

- Circuit interrupters that are rated well below the battery's peak current source capability shall be installed in the battery power circuit. Interrupters may be fuses, circuit breakers, thermal switches, PTCs, or other effective devices. Circuit interrupters other than fuses shall be rated at a value that is equal to or lower than the maximum current that the cell is capable of handling without causing venting, smoke, explosion, fire, or thermal runaway.
- The battery case is usually grounded/bonded to the structure; the interrupters should be in the ground (negative) leg of a battery where the negative terminal is connected to ground. Where the circuit is "floating," as in plastic battery cases used in those for portable electronic devices, the circuit interrupters can be placed in either leg. In either case, the circuit interrupters should be placed as close to the cell or battery terminals as the design will allow maximizing the zone of protection.
- All inner surfaces of metal battery enclosures should be anodized and/or coated with a non-electrically conductive electrolyte-resistant paint to prevent a subsequent short circuit hazard (if applicable).
- The surfaces of battery terminals on the outside of the battery case should be protected from accidental bridging.
- Battery terminals that pass through metal battery enclosures should be insulated from the case by an insulating collar or other effective means.
- Wires inside the battery case should be insulated, restrained from contact with cell terminals, protected against chafing, and physically constrained from movement due to vibration or shock.
- In battery designs greater than 50 Vdc, corona-induced short circuits (high-voltage induced gas breakdown) shall be prevented.

4.4.7.6 Overvoltage and Undervoltage Protection

Protection circuitry and safety features shall be implemented at the cell level to prevent overvoltage or undervoltage conditions of the cell.

4.4.7.7 Battery Charging

It should be verified that the battery charging equipment (if not the dedicated charger) has at least two levels of control that will prevent it from causing a hazardous condition on the battery being charged.

Note: This does not apply if the CubeSat will not be charged at Nanoracks.

4.4.7.8 Battery Energy Density

Battery designs greater than 80 Wh energy employing high specific energy cells (greater than 80 watt-hours/kg, for example, lithium-ion chemistries) require additional assessment by Nanoracks due to potential hazard in the event of single-cell, or cell-to-cell thermal runaway.

Note: Any system over 80 Wh will require additional design scrutiny and testing (likely including destructive thermal runaway testing). It is possible that this additional testing may be avoided by implementing design features in the system, such as splitting up the cells into distinct battery packs less than 80 Wh and physically isolating them at opposite ends of the CubeSat (so that thermal runaway cannot propagate between packs). Other methods, such as reducing the state of charge of the batteries at the time of delivery, can be explored with the JSC Battery Safety team to reduce the risk of a thermal runaway event.

4.4.7.9 Lithium Polymer Cells

Lithium Polymer Cells i.e. “pouch cells” shall be restrained at all times to prevent inadvertent swelling during storage, cycling, and low pressure or vacuum environments with pressure restraints on the wide faces of the cells to prevent damage due to pouch expansion. Coordinate with Nanoracks for guidance on specific implementation.

4.4.7.10 Button Cells

Button cell or coin cell batteries are often used in COTS components to power real-time clocks (RTCs), watch-dog circuits, or secondary systems for navigation, communication, or attitude control. These batteries shall be clearly identified by part number and UL listing.

Note: Flight acceptance screening testing of these cells is typically not required. Only a functional test of the system needs to be reported. Nanoracks will confirm requirements upon documentation of all coin cell part numbers in the unique payload ICA.

4.4.7.11 Capacitors Used as Energy Storage Devices

Capacitors are used throughout today's modern electronics. Capacitors used as energy storage devices are treated and reviewed like batteries. Hazards associated with leaking electrolyte can be avoided by using solid state capacitors. Any wet capacitors that utilize liquid electrolyte must be reported to NASA. The capacitor part number and electrolyte must be identified along with details of how the capacitor is used and any associated schematics.

Note: Nanoracks will advise on any required flight acceptance screening testing once the information has been captured in the payload unique ICA.

4.4.8 Pressure System

A pressure *system* is classified in SSP 51721 as a low pressure or high pressure system and can contain fluids or gasses that are considered either hazardous or nonhazardous. A pressure *vessel* is defined by SSP 52005 as any sealed container with an internal pressure greater than 100 psia. A pressure vessel may be made acceptable for Flight Safety with proper controls for any hazard potential both for inside ISS and outside ISS. If a satellite has a pressure vessel, the PD shall provide documentation with respect to the materials used, tank history (including cycles and life time assessment) and control measures taken to assure tank integrity (damage control plan), testing performed, fracture control measures planned, inspection process and methods, etc. wherever hazard potential is present. All pressure vessels shall be certified by the Department of Transportation (DOT) or have a DOT issued waiver for transportation across the US. Use of non-DOT certified pressure vessels generally would not be permitted. Exceptions must be coordinated with Nanoracks during the pre-contract signing phase. Systems will have to demonstrate via test that required factors of safety are present for tanks, lines and fittings that can be exposed to pressure with 1 or 2 failures depending on hazard potential. Pressure vessels and components procured from third party vendors must have proper certification records or the PD must develop the appropriate records to assure that the systems are safe by meeting NASA requirements. Nanoracks will assist in negotiating with NASA to define the work and analysis necessary to meet the NASA requirements.

4.4.9 Propulsion System

The propulsion system will need to be assessed for hazard potential. Nanoracks will assist in the identification of hazards. Mechanical hazards may be related to pressure containment, flow containment, leakage, etc. Systems may also have hazard potential if inadvertent operation of the propulsion system in or around ISS could be catastrophic or critical. Depending on hazard potential, both mechanical and electrical fault tolerance may be required.

Systems with toxic propellant may not be allowed onboard ISS but might be approvable if outside ISS. Propellants with explosive potential may not be approvable. Acceptable propellant type must be coordinated with Nanoracks and documented in the ICA.

4.4.10 Lasers

The laser system will need to be assessed for hazard potential. Nanoracks will assist in the identification of hazards. The basis of hazard classification is the ability of the laser beam to cause biological damage to the eye or skin during use (SSP 57121 Section 4.9.4.1). The hazard potential of lasers is dependent on several factors including the laser class. Laser class is determined by vendor-provided data or test of the laser at source, both with concurrence of the JSC/NIR group.

Class 1M and 2M lasers are considered potentially hazardous if viewed with certain optical aids. Class 3R, 3B and 4 Lasers shall be inaccessible to the crew or provided with three controls to prevent exposure. These lasers can be hazardous to the eye or skin from direct beam or specular reflection viewing conditions. Class 4 lasers could also pose a diffuse reflection or fire hazard. Crew exposure to Class 3R, 3B or 4 lasers is considered a catastrophic hazard.

4.4.11 High Voltage System

A high voltage (HV System) is considered any component of the CubeSat's hardware that is greater than 32V. HV systems pose a hazard of crew electric shock during mate/demate of the system's connections. This hazard is prevented by isolating electric currents from crew accessible surfaces with high voltages. Nanoracks will request additional information to conduct a wire derating analysis if this hazard is deemed present.

4.4.12 Magnets

Magnets within the satellite shall comply with SSP57000 (Rev U) Section 3.2.2.4 stating the magnets shall not generate static magnetic flux density exceeding 3.16 Gauss at a distance of 7 cm from the surface of the source. This applies to both electromagnetic and permanent magnetic devices.

4.4.13 Materials

4.4.13.1 Stress Corrosion Materials

Stress corrosion resistant materials from Table I of MSFC-SPEC-522 are preferred. Any use of stress corrosion susceptible materials (Table II) shall be coordinated with Nanoracks and documented in the ICA. Any use of Table III materials shall be avoided.

4.4.13.2 Hazardous Materials

Satellites shall comply with JSC 27472 (Rev B), JSC 63838 (Rev B), JSC 66869, and applicable NASA guidelines for hazardous materials. Beryllium, cadmium, mercury, silver or other materials prohibited by SSP-30233 shall not be used. Any use of hazardous materials shall be coordinated with Nanoracks and documented in the ICA.



4.4.13.3 Outgassing / External Contamination

Satellites shall comply with NASA guidelines for selecting all non-metallic materials based on available outgassing data. Satellites shall not utilize any non-metallic materials with a Total Mass Loss (TML) greater than 1.0 percent or a Collected Volatile Condensable Material (CVCM) value of greater than 0.1 percent.

Note: A Bill of Materials (BoM) must be provided to Nanoracks to verify all materials requirements are met. The BoM shall be provided in the template specified by Nanoracks and must include the vacuum-exposed surface areas of all non-metals. The ISS Space Environments Team screens the BoMs to ensure there are no external contamination concerns due to high-outgassing components. A bake-out is not required. The NASA website linked below is a useful source for obtaining outgassing data for materials.

<https://outgassing.nasa.gov/>

4.4.14 Additively Manufactured (3D-Printed) Materials

Satellites shall comply with NASA guidelines for selecting all additively manufactured (3D-Printed) materials based on available outgassing data. The payload developer must coordinate with Nanoracks to ensure structural integrity and conformity with NASA outgassing requirements of the additively manufactured material.

4.4.15 Electrical Bonding

All spacecraft components shall be electrically bonded per SSP 30245 to ensure the spacecraft is free from electrical shock and static discharge hazards. Typically, spacecraft components may be bonded by either nickel plating or chemical film treated faying surfaces or dedicated bonding straps.

4.5 Jettison Requirements

The insertion parameters of the CubeSat are dictated by the NRCSD and therefore the jettison approval process is coordinated by Nanoracks based on inputs provided by the PD. However, payloads should be aware of the following criteria as a minimum. Special cases where post-deploy collision controls necessitate other criteria are possible.

4.5.1 CubeSats with Propulsion

Satellites with propulsion and maneuvering capability (including use for attitude control) require further assessment by Nanoracks. The payload developer shall submit an analysis that outlines maximum theoretical dV capability for Nanoracks preliminary assessment prior for feasibility study.



Note: The information above is provided so that Nanoracks can characterize the capabilities of any propulsion system. All propulsion systems will be subject to a feasibility assessment with the ISS Program prior to manifesting for flight.

4.5.2 Re-entry Survivability

- 1) CubeSats over 5kg shall provide an Orbital Debris Assessment Report (ODAR) that verifies compliance with NASA-STD-8719.14.
- 2) CubeSats that are designed to survive re-entry or have components that are designed to survive re-entry shall provide an ODAR that verifies compliance with NASA-STD-8719.14.

Note: Any payload that is designed to survive re-entry may require additional data submittals or justification that will be handled on a case-by-case basis and documented in the payload unique ICA.

4.6 Documentation Requirements

4.6.1 Regulatory Compliance

The CubeSat developer shall submit evidence of all regulatory compliance for spectrum utilization and remote sensing platforms prior to handover of the payload. This evidence shall come in the form of the authorization or license grant issued directly from the governing body / agency (which is dependent on the country the CubeSat originates).

Note: Nanoracks is not responsible for facilitating the licensure effort for spectrum and remote sensing authorization but is required to provide ISS Program with proof of compliance prior to delivering the payload for launch.

For United States (US) CubeSats, the governing body for spectrum authorization is the Federal Communications Commission (FCC) unless the payload is government owned / operated, in which case the regulatory body is the National Telecommunications and Information Administration (NTIA). The governing body for US CubeSats with remote sensing platforms is the National Oceanic and Atmospheric Administration (NOAA), which is not required if the payload is government owned / operated.

For non-US CubeSats, proof of regulatory compliance with appropriate domestic agencies and the International Telecommunication Union (ITU) coordination details shall be provided.

Nanoracks is not responsible for facilitating the licensure effort but is required to provide ISS Program with proof of compliance prior to delivering the payload for launch.

4.6.2 Documentation

In addition to the payload unique ICA, payload providers will be required to provide various documents and progress reports throughout the flight safety and verification process. Table 4.6.2- captures the major documents that are required. Note that the deliverables outlined below may not apply to all payloads and in turn additional documentation may be required at the discretion of Nanoracks. The required documentation for verification shall be captured in the unique payload ICA.

Table 4.6.2-1: Data Deliverables

Item	Deliverable	Description
1	Safety Data Template	Summary of Satellite Design: requires filling in Nanoracks template with basic satellite design information appropriate for processing the satellite through the Safety Review Process.
2	Bill of Materials	To be utilized for external outgassing contamination assessment and formation of Materials Identification Usage List (MIUL).
3	Battery Test Report	Test report shows compliance with work instruction provided by Nanoracks.
4	Vibration Test Report	Integrated test report outlining test set-up, as-run accelerometer response plots, and post-vibration functional and inspection results.
5	Investigation Summary Form	Template provided by Nanoracks documenting the science objectives of the payload for use on public NASA webpage.
6	Final Satellite As-Measured Mass Properties	Mass and CM (Mass Measured, CM Calculated)
7	Power System Functional Test Report for EPS inhibits verification	For safety inhibits part of the spacecraft EPS system.
8	Pressure System Qualification Test Report (if Qual Test is performed)	If Pressure Systems are onboard the payload
9	Provide Pressure System Acceptance Test Report	If Pressure Systems are onboard the payload
10	Materials Compatibility Report for Pressure System	If Pressure Systems are onboard the payload
11	Structural Analysis	NR to provide specific guidance on what is required depending on the hazard classification of the payload.
12	Inspection Reports for fracture critical parts (if any fracture critical parts)	
13	Inspection Reports for stress corrosion parts (if any stress corrosion sensitive parts)	

5 Requirements Matrix

The NRCSD Requirements Matrix assists in validating whether a CubeSat adheres to the specifications outlined in the Interface Definitions Document. Although it contains all relevant sections of the IDD, this matrix is not an official certification of CubeSat compliance with Nanoracks requirements. The Verification Method abbreviations are listed here for reference:

- A: Analysis
- I: Inspection
- T: Testing

Table 5-1: Nanoracks CubeSat Deployer Requirements Matrix

Paragraph Number	Paragraph Title	Requirement Text	Verification Method	Submittal Data Type
4.1.1-1	Rail Specification	The CubeSat shall have four (4) rails along the Z axis, one per corner of the payload envelope, which allow the payload to slide along the rail interface of the NRCSD as outlined in Error! Reference source not found.	I, T	Engineering Drawing, Fit Check ROA
4.1.1-2	Rail and Envelope Dimensions	The CubeSat rails and envelope shall adhere to the dimensional specification outlined in Error! Reference source not found.	I, T	Engineering Drawing, Fit Check ROA
4.1.1-3	Rail Width	Each CubeSat rail shall have a minimum width (X and Y faces) of 6mm.	I, T	Engineering Drawing, Fit Check ROA
4.1.1-4	Rail Edge Radius	The edges of the CubeSat rails shall have a radius of 0.5mm +/- 0.1mm.	I	Engineering Drawing
4.1.1-5	CubeSat Load Points	The CubeSat +Z rail ends shall be completely bare and have a minimum surface area of 6mm x 6mm.	I	Engineering Drawing
4.1.1-6	Rail Design Tolerance	The CubeSat rail ends (+/-Z) shall be coplanar with the other rail ends within +/- 0.1mm.	I	Engineering Drawing
4.1.1-7	Rail Length	The CubeSat rail length (Z axis) shall be the following (+/- 0.1mm): a. 1U rail length: 113.50mm b. 2U rail length: 227.00mm c. 3U rail length: 340.50mm d. 4U rail length: 454.00mm	I, T	Engineering Drawing, Fit Check ROA

		e. 5U rail length: 567.5mm f. 6U rail length: 681 to 740.00mm		
4.1.1-8	Rail Continuity	The CubeSat rails shall be continuous. No gaps, holes, fasteners, or any other features may be present along the length of the rails (Z-axis) in regions that contact the NRCSD rails.	I	Engineering Drawing
4.1.1-9	Rail Envelope	The <i>minimum</i> extension of the +/-Z CubeSat rails from the +/-Z CubeSat faces shall be 2mm.	I	Engineering Drawing
4.1.1-10	Mechanical Interface	The CubeSat rails shall be the only mechanical interface to the NRCSD in all axes (X, Y and Z axes).	I, T	Engineering Drawing, Fit Check ROA
4.1.1-11	Rail Hardness	The CubeSat rail surfaces that contact the NRCSD guide rails shall have a hardness equal to or greater than hard-anodized aluminum (Rockwell C 65-70).	I	Materials List
4.1.1-12	Surface Roughness	The CubeSat rails and all load points shall have a surface roughness of less than or equal to 1.6 μm .	I	Materials List
4.1.2-1	Mass Limits	The CubeSat mass shall be less than the maximum allowable mass for each respective payload form factor per Table 4.1.2-1	T	Integration ROA
4.1.2-2	Center of Mass	The CubeSat center of mass (CM) shall be located within the following range relative to the geometric center of the payload. a. X-axis: (+/- 2cm) b. Y-axis: (+/- 2cm) c. Z-axis: i. 1U: (+/- 2cm) ii. 2U (+/- 4cm) iii. 3U (+/- 6cm) iv. 4U (+/- 8cm) v. 5U (+/- 10cm)	I	Safety Data Template

		vi. 6U (+/- 12cm)		
4.1.3-1	RBF / ABF Access	The CubeSat shall have a remove before flight (RBF) feature or an apply before flight (ABF) feature that is physically accessible via the NRCSD access panels on the +Y face of the dispenser.	I, T	Engineering Drawing, Fit Check ROA
4.1.4-1	Deployment Switch Requirement	The CubeSat shall have a minimum of three (3) deployment switches that correspond to independent electrical inhibits on the main power system (see section on electrical interfaces).	I, T	Electrical Schematic, Fit Check ROA
4.1.4-2	Plunger Switch Location	Deployment switches of the pusher/plunger variety shall be located on the rail end faces of the CubeSat's -Z face.	I, T	Electrical Schematic, Fit Check ROA
4.1.4-3	Roller Switch Location	Deployment switches of the roller/lever variety shall be embedded in the CubeSat rails (+/- X or Y faces).	I, T	Electrical Schematic, Fit Check ROA
4.1.4-4	Switch Contact Surface Area	Roller/slider switches shall maintain a minimum of 75% surface area contact with the NRCSD rails (ratio of switch contact to NRCSD guide rail width) along the entire Z axis.	I	CAD
4.1.4-5	Switch Reset	The CubeSat deployment switches shall reset the payload to the pre-launch state if cycled at any time within the first 30 minutes after the switches close (including but not limited to radio frequency transmission and deployable system timers).	I	Safety Data Template
4.1.4-6	Switch Captivation	The CubeSat deployment switches shall be captive.	I	Engineering Drawing
4.1.4-7	Switch Force	The force exerted by the deployment switches shall not exceed 3N.	I	Switch Datasheet

4.1.4-7	Total Switch Force	The total force of all CubeSat deployment switches shall not exceed 9N.	I	Switch Datasheet
4.1.5-1	Deployable Systems Restraint Mechanisms	CubeSat deployable systems (such as solar arrays, antennas, payload booms, etc.) shall have independent restraint mechanisms that do not rely on the NRCSD dispenser.	I, T	Safety Data Template, Fit Check ROA
4.2	Electrical System Interface Requirements	-	-	-
4.2.1	Electrical System Design	-	-	-
4.2.1-1	Power Storage Device Location	All electrical power storage devices shall be internal to the CubeSat.	I	Safety Data Template
4.2.1-2	Post-Deployment Timer	CubeSat shall not intentionally operate any mechanical, deployable, or communication systems (including RF transmitters, deployment mechanisms or other subsystems) for a minimum of 30 minutes post deployment where hazard potential exists. Satellites shall have a timer (set to a minimum of 30 minutes and require appropriate fault tolerance) before satellite operation or deployment of appendages where hazard potential exists.	I, T	Safety Data Template
4.2.1-3	Electrical Inhibits	The CubeSat electrical system design shall incorporate a minimum of three (3) independent inhibit switches actuated by physical deployment switches as shown in Figure 4.2-1. The satellite inhibit scheme shall include a ground leg inhibit (switch D3 on Figure 4.2-1) that disconnects the batteries along the power	I	Electrical Schematic

		line from the negative terminal to ground.		
4.2.1-4	Ground Circuit	The CubeSat electrical system design shall not permit the ground charge circuit to energize the satellite systems (load), including flight computer (see Figure 4.2-1). This restriction applies to all charging methods.	I	Electrical Schematic
4.2.1-5	RBF / ABF Requirement	The CubeSat shall have a remove before flight (RBF) feature or an apply before flight (ABF) feature that keeps the satellite in an unpowered state throughout the ground handling and integration process into the NRCSD.	I, T	Electrical Schematic, Fit Check ROA
4.2.1-6	RBF / ABF Functionality	The RBF /ABF feature shall preclude any power from any source operating any satellite functions except for pre-integration battery charging.	I	Electrical Schematic
4.2.1-7	Wire Requirement	The CubeSat Electronics Power System (EPS) shall have no more than six (6) inches of wire 26AWG or larger between the power source (i.e. battery pack) and the first electrical inhibit (MOSFET or equivalent).	I	Safety Data Template
4.3.2-1	Random Vibration Environment	The CubeSat shall be capable of withstanding the random vibration environment for flight with appropriate safety margin as outlined in Section 4.3.2.1.	T	Vibration Test Report
4.3.5	Integrated Loads Environment	The CubeSat shall be capable of withstanding a force 1200N across all load points equally in the Z direction.	I	Safety Data Template
4.3.8	Airlock Depressurization	The CubeSat shall be capable of withstanding the pressure extremes and depressurization / pressurization rate of the airlock as defined in Section 4.3.8	I	Safety Data Template

4.4.6-1	CubeSat Sub-Deployables	CubeSats shall not have detachable parts during launch or normal mission operations. Any exceptions will be coordinated with Nanoracks and documented in the unique payload ICA.	I	Safety Data Template
4.4.6-2	Space Debris Compliance	CubeSats shall comply with NASA space debris mitigation guidelines as documented in NASA Technical Standard NASA-STD-8719.14A.	A	ODAR
4.4.7.3	Battery Testing	All flight cells and battery packs shall be subjected to an approved set of acceptance screening tests to ensure the cells will perform in the required load and environment without leakage or failure. While the specific test procedures vary depending on the type of battery, the majority of Lithium ion or Lithium polymer cells / batteries used in CubeSats can be tested to a standard statement of work issued by Nanoracks (NR-SRD-139).	T	Battery Test Report
4.4.7.4	Internal Short Circuit	Protection circuitry and safety features shall be implemented at the cell level to prevent an internal short circuit.	I	Electrical Schematic
4.4.7.5	External Short Circuit	Protection circuitry and safety features shall be implemented at the cell level to prevent an external short circuit.	I	Electrical Schematic
4.4.7.6	Overvoltage & Undervoltage Protection	Protection circuitry and safety features shall be implemented at the cell level to prevent overvoltage or undervoltage conditions of the cell.	I, T	Electrical Schematic, Battery Test Report
4.4.7.7	Battery Charging	It should be verified that the battery charging equipment (if not the dedicated charger) has at least two levels of control that will prevent it from causing a	I	Electrical Schematic

		hazardous condition on the battery being charged.		
4.4.7.8	Battery Energy Density	For battery designs greater than 80 Wh energy employing high specific energy cells (greater than 80 watt-hours/kg, for example, lithium-ion chemistries) require additional assessment by Nanoracks due to potential hazard in the event of single-cell, or cell-to-cell thermal runaway.	I, T	Electrical Schematic, Battery Test Report
4.4.7.9	Pouch Cell Expansion	Lithium Polymer Cells i.e. "pouch cells" shall be restrained at all times to prevent inadvertent swelling during storage, cycling, and low pressure or vacuum environments with pressure restraints on the wide faces of the cells to prevent damage due to pouch expansion.	I	Safety Data Template
4.4.7.10	Button Cell Batteries	Button cell or coin cell batteries are often used in COTS components to power real-time clocks (RTCs), watch-dog circuits, or secondary systems for navigation, communication, or attitude control. These batteries shall be clearly identified by part number and UL listed or equivalent.	I	Safety Data Template
4.4.7.11	Capacitors	Capacitors used as energy storage devices are treated and reviewed like batteries. Hazards associated with leaking electrolyte can be avoided by using solid state capacitors. Any wet capacitors that utilize liquid electrolyte must be reported to NASA. The capacitor part number and electrolyte must be identified along with details of how the capacitor is used and any associated schematics.	I	Safety Data Template

4.4.12	Magnets	Magnets within the satellite shall comply with SSP57000 (Rev U) Section 3.2.2.4 stating the magnets shall not generate static magnetic flux density exceeding 3.16 Gauss at a distance of 7 cm from the surface of the source. This applies to both electromagnetic and permanent magnetic devices.	A	Safety Data Template
4.4.13.1	Stress Corrosion Materials	Stress corrosion resistant materials from Table I of MSFC-SPEC-522 are preferred. Any use of stress corrosion susceptible materials (Table II) shall be coordinated with Nanoracks and documented in the ICA. Any use of Table III materials shall be avoided.	I	Bill of Materials
4.4.13.2	Hazardous Materials	Satellites shall comply with NASA guidelines for hazardous materials. Beryllium, cadmium, mercury, silver or other materials prohibited by SSP-30233 shall not be used.	I	Bill of Materials
4.4.13.3	Outgassing / External Contamination	Satellites shall comply with NASA guidelines for selecting all non-metallic materials based on available outgassing data. Satellites shall not utilize any non-metallic materials with a Total Mass Loss (TML) greater than 1.0 percent or a Collected Volatile Condensable Material (CVCM) value of greater than 0.1 percent.	I	Bill of Materials
4.5.2-1	Orbital Debris Mass Requirement	CubeSats over 5kg shall provide an Orbital Debris Assessment Report (ODAR) that verifies compliance with NASA-STD-8719.14.	A	ODAR, DAS Input File
4.5.2-2	Re-entry Survivability	CubeSats that are designed to survive re-entry or have	A	ODAR



		components that are designed to survive re-entry shall provide an ODAR that verifies compliance with NASA-STD-8719.14.		
4.6.1	Regulatory Compliance	The CubeSat developer shall submit evidence of all regulatory compliance for spectrum utilization and remote sensing platforms prior to handover of the payload. This evidence shall come in the form of the authorization or license grant issued directly from the governing body / agency (which is dependent on the country the CubeSat originates).	I	Regulatory Licenses

Certificate Of Completion

Envelope Id: 6E79CA17422949DA884B378BED720F89	Status: Completed
Subject: SIGNATURE NEEDED: NR-NRCSD-S0003 (RevA) VS Branding - Website Use	
Source Envelope:	
Document Pages: 54	Signatures: 1
Certificate Pages: 1	Initials: 0
AutoNav: Enabled	Envelope Originator:
Envelope Stamping: Enabled	Jennifer Corder
Time Zone: (UTC-08:00) Pacific Time (US & Canada)	503 Forge River Road
	503 Forge River Road
	Webster, TX 77598
	jcorder@nanoracks.com
	IP Address: 162.248.186.11

Record Tracking

Status: Original	Holder: Jennifer Corder	Location: DocuSign
1/26/2024 7:57:52 AM	jcorder@nanoracks.com	

Signer Events

Doc Control Web Use
 jcorder@nanoracks.com
 Nanoracks
 Security Level: Email, Account Authentication (None)

Signature

DocuSigned by:

 Signature Adoption: Uploaded Signature Image
 Using IP Address: 161.199.216.39
 Signed using mobile

Timestamp

Sent: 1/26/2024 7:59:07 AM
 Viewed: 1/26/2024 7:59:32 AM
 Signed: 1/26/2024 7:59:38 AM

Electronic Record and Signature Disclosure:
 Not Offered via DocuSign

In Person Signer Events

Signature

Timestamp

Editor Delivery Events

Status

Timestamp

Agent Delivery Events

Status

Timestamp

Intermediary Delivery Events

Status

Timestamp

Certified Delivery Events

Status

Timestamp

Carbon Copy Events

Status

Timestamp

Witness Events

Signature

Timestamp

Notary Events

Signature

Timestamp

Envelope Summary Events

Status

Timestamps

Envelope Sent	Hashed/Encrypted	1/26/2024 7:59:07 AM
Certified Delivered	Security Checked	1/26/2024 7:59:32 AM
Signing Complete	Security Checked	1/26/2024 7:59:38 AM
Completed	Security Checked	1/26/2024 7:59:38 AM

Payment Events

Status

Timestamps