

VANTAGESUN Coarse

OVERVIEW

USA-sourced and manufactured, the highly reliable VantageSun Coarse sun sensor has more than 20 years of spaceflight heritage. This low-cost, single-axis, coarse-resolution sun sensor has a simple, reliable design. It contains a single-channel photodiode and the housing assembly serves as an aperture, reducing mechanical complexity and precisely masking solar light.

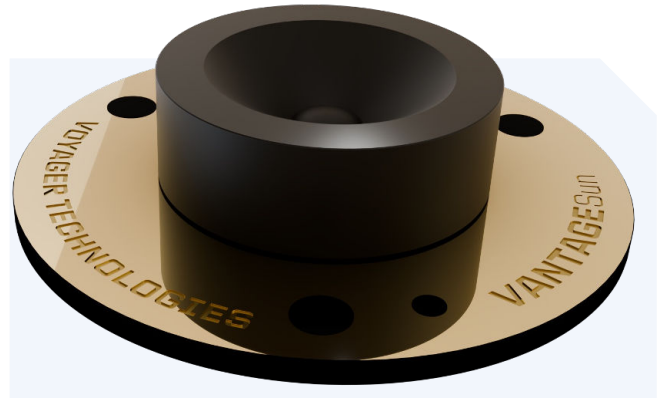

KEY FEATURES

- 1-axis accuracy better than 5° over full FoV
- Passive device draws no power
- Low mass less than 10g for all configurations
- Calibration data provided with each sensor

APPLICATIONS

- Attitude determination during:
 - Launch vehicle separation
 - Initial attitude acquisition
 - Emergencies and off-nominal modes
- Sun vector determination

PRODUCT SPECIFICATIONS

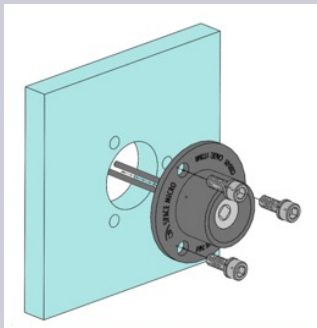
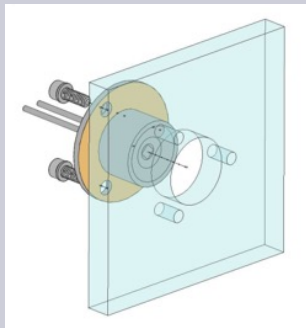
	CSS-01	CSS-02
Field of View	120° Full Angle Circular	
Accuracy	<5°	
Interfaces	0 to 3.5 mA (typical) current sources Two flying leads, 1.27m (50") length M22759/33-26 26 AWG wire	
Mounting		

VANTAGESUN Coarse

PRODUCT SPECIFICATIONS

Environment Temperature Range Vibration Suitability	-40°C to +100°C (Operating), -55°C to +125°C (Storage) GFSC-STD-7000 (NASA GEVS) Acceptance Level All Orbits – LEO, MEO, GEO, Cislunar, and beyond
SWaP Dimensions Mass Power	Housing Diameter: 12.70mm Flange Diameter: 22.86mm Sensor Height: 8.99mm <10g including flying leads None required

DIMENSIONS

CSS-01 / CSS-02

